



MCFARLAND CITY COUNCIL

McFarland Successor Agency, McFarland Public Finance Authority,
McFarland Improvement Authority, McFarland Parking Authority

Regular Meeting Notice and Agenda

Council Chambers
103 W. Sherwood Ave, McFarland, CA
Website: <https://www.mcfarlandcity.org/>

Wednesday, July 9, 2025
6:00 PM

SAUL AYON, *Mayor*
RICARDO CANO, *Vice Mayor*
MARTIN GUTIERREZ, *Council Member*
ANITA GONZALEZ, *Council Member*
MARÍA T. PÉREZ, *Council Member*

VIEW THE MEETING RECORDINGS ONLINE at www.mcfarlandcity.org/AgendaCenterRecordings will be available approximately one week following the meeting.

HOW TO SUBMIT PUBLIC COMMENTS: The meetings of the City Council and all municipal entities, commissions, and boards (“the City”) are open to the public. At regularly scheduled meetings, members of the public may address the city on any item listed on the agenda, or on any non-listed matter over which the city has jurisdiction. At special or emergency meetings, members of the public may only address the city on items listed on the agenda. There is a time limitation of two minutes per person. For any item that is not on the agenda and within the jurisdiction or interest of the city, please come to the podium at this time. The Brown Act does not permit any action or discussion on items not listed on the agenda. If you wish to speak regarding a scheduled agenda item, please come to the podium when the item number and subject matter are announced, and the mayor opens Public Comment on the item. When recognized, please begin by providing your name and address for the record (optional). Anyone wishing to submit written information at the meeting needs to furnish ten (10) copies to the City Clerk in advance to allow for distribution to City Council, staff, and the media. Willful disruption of the meeting shall not be permitted. If the Mayor finds that there is in fact willful disruption of any City Council Meeting, he/she may order the disrupting parties out of the room and subsequently conduct the City’s business without them present.

PUBLIC ACCOMMODATIONS: The City of McFarland does not discriminate based on disability and complies with the provisions of the Americans with Disabilities Act (ADA). If you need special assistance to participate in this meeting, please contact the City Clerk’s Office at (661) 792-3091 at least 48 hours prior to the meeting to make reasonable arrangements to ensure accessibility to this meeting.

INTERPRETATION: If you need an interpretation of your communications to the City Council into English, please contact the City Clerk Department at 661-792-3091 ext. 2135 at least 48 hours prior to the meeting.

CALL TO ORDER: Mayor Saul Ayon

ROLL CALL:
Mayor/Chair, Saul Ayon

Vice Mayor/Vice-Chair, Ricardo Cano
Council Member/Board Member, Martin Guterrez
Council Member/Board Member, Anita Gonzalez
Council Member/Board Member, María T. Pérez

INVOCATION: Pastor Jim Beltran

PLEDGE OF ALLEGIANCE: Jim White

APPROVE AGENDA AS TO FORM

FEATURED PET:

Is a feature that highlights a pet available for adoption from the McFarland Animal Shelter.

- Featured Pet Presented by Chief of Police Knox

PRESENTATIONS, INTRODUCTIONS AND AWARDS

DEPARTMENTAL REPORTS

CONSENT AGENDA: The Consent Agenda consists of items that in staff's opinion are routine and non-controversial. These items are approved in one motion unless a Council Member/ Board Member or Member from the Public requests to remove a particular item.

1. Approval of Expense Report in the Amount of \$304,380.54 from 6/14/2025 to 6/27/2025.
2. Approval of Payroll Report for the Month of June 2025 in the Amount of \$394,317.79
3. Approval of June 25, 2025, Regular Meeting Minutes
4. Approval of Resolution No. 2025-97 A RESOLUTION OF THE CITY COUNCIL OF THE CITY OF MCFARLAND AUTHORIZING THE DESIGNATION OF THE CITY MANAGER AS THE AUTHORIZED REPRESENTATIVE TO SIGN AND FILE A FINANCIAL ASSISTANCE APPLICATION FOR A FINANCING AGREEMENT FROM THE STATE WATER RESOURCE CONTROL BOARD
5. Approval of Resolution No. 2025-95 A RESOLUTION OF THE CITY COUNCIL OF THE CITY OF MCFARLAND AUTHORIZING THE CITY MANAGER TO EXECUTE A MEMORANDUM OF UNDERSTANDING BETWEEN THE GEO GROUP, INC. AND THE CITY OF MCFARLAND POLICE DEPARTMENT
6. Approval of Resolution No. 2025-96 A RESOLUTION OF THE CITY COUNCIL OF THE CITY OF MCFARLAND AUTHORIZING THE FILING OF AN APPLICATION FOR CONGESTION MITIGATION AIR QUALITY PROGRAM FUNDING AND COMMITTING THE NECESSARY LOCAL MATCH AND STATING THE ASSURANCE TO COMPLETE THE PROJECT
7. Approval of Resolution No. 2025-93 A RESOLUTION OF THE CITY COUNCIL OF THE CITY OF MCFARLAND APPROVING THE AUTHORIZATION TO SUBMIT A REGIONAL SURFACE TRANSPORTATION (RSTP) APPLICATION TO KERN COG FOR THE REHABILITATION OF W. PERKINS AVENUE FROM 5TH STREET TO FRONTAGE ROAD
8. Approval of Resolution No. 2025-94 A RESOLUTION OF THE CITY COUNCIL

APPROVING THE COST FOR REPAIR OF THE ELGIN STREET SWEEPER AND
AUTHORIZING THE USE OF ALLOCATED FUNDS

9. Approval of Resolution No. 2025-91 A RESOLUTION OF THE CITY COUNCIL OF THE CITY OF MCFARLAND APPROVING THE AMENDMENT TO RETENTION INCENTIVE AGREEMENT- CLARIFICATION OF REPAYMENT TERMS AND MODIFICATION OF PAYMENT STRUCTURE

PUBLIC HEARINGS

10. Approval of Resolution No. 2025-90 A RESOLUTION OF THE CITY COUNCIL OF THE CITY OF MCFARLAND CALLING FOR THE HOLDING OF A SPECIAL MUNICIPAL ELECTION TO BE HELD ON TUESDAY NOVEMBER 4, 2025 FOR THE SUBMISSION OF A BALLOT MEASURE TO ADOPT AN ORDINANCE APPROVING TRANSACTIONS AND USE GENERAL TAX TO BE ADMINISTERED BY THE CALIFORNIA DEPARTMENT OF TAX AND FEE ADMINISTRATION
11. Approval of Resolution No. 2025-82 TO APPROVE THE CANCELLATION OF LAND USE RESTRICTIONS, LAND CONSERVATION ACT, AGRICULTURE PRESERVE NO. 7 AND AMENDING LAND USE CONTRACT

ADMINISTRATIVE AGENDA

12. Approval of Resolution No. 2025-98 A RESOLUTION OF THE CITY COUNCIL OF THE CITY OF MCFARLAND RATIFYING THE PURCHASE AND INSTALLATION OF TRAFFIC CALMING MEASURES ON MAST AVE

PUBLIC COMMENT: Members of the public wishing to address the Council about any item not on the agenda may do so at this time. Speakers are limited to two minutes for each person. Fifteen minutes total will be allowed for any one subject. Please state your name and address for the record prior to making a presentation.

COUNCIL COMMENTS

COUNCIL STATEMENTS AND REPORTS:

On their own initiative, Council Members may make a brief announcement or a brief report on their own activities. In addition, Council Members may ask a question of staff or the public for clarification on any matter, provide a reference to staff or other resources for information. Alternatively, request staff to report to the City Council at a later meeting concerning any matter. Furthermore, the City Council, or any member thereof, may take action to direct staff to place a matter of business on a future agenda.

CLOSED SESSION

ADJOURNMENT

This is to certify this agenda was posted at McFarland City Hall on July 3, 2025.

Erika De La Cruz

Erika De La Cruz, City Clerk

Diego Viramontes

Diego Viramontes, City Manager

Next Meeting: Regular City Council July 23, 2025

The City of McFarland does not discriminate based on disability and complies with the provisions of the Americans with Disabilities Act (ADA). If you need special assistance to participate in this meeting, please contact the City Clerk's Office at (661) 792-3091 at least 48 hours prior to the meeting to make reasonable arrangements to ensure accessibility to this meeting. Special meeting needs hour change

All agenda item and/or supporting documentation is available for public review on the city website at www.mcfarlandcity.org and the office of the City Clerk of the City of McFarland, at 401 W, Kern Ave. McFarland, CA 93250 during regular business hours of 8:00 am – 5:00 pm Monday through Friday, following the posting of the agenda. Any supporting documentation related to an agenda item for an open session of any regular meeting that is distributed after the agenda is posted and prior to the meeting will also be available for review at the same location and available at the meeting.

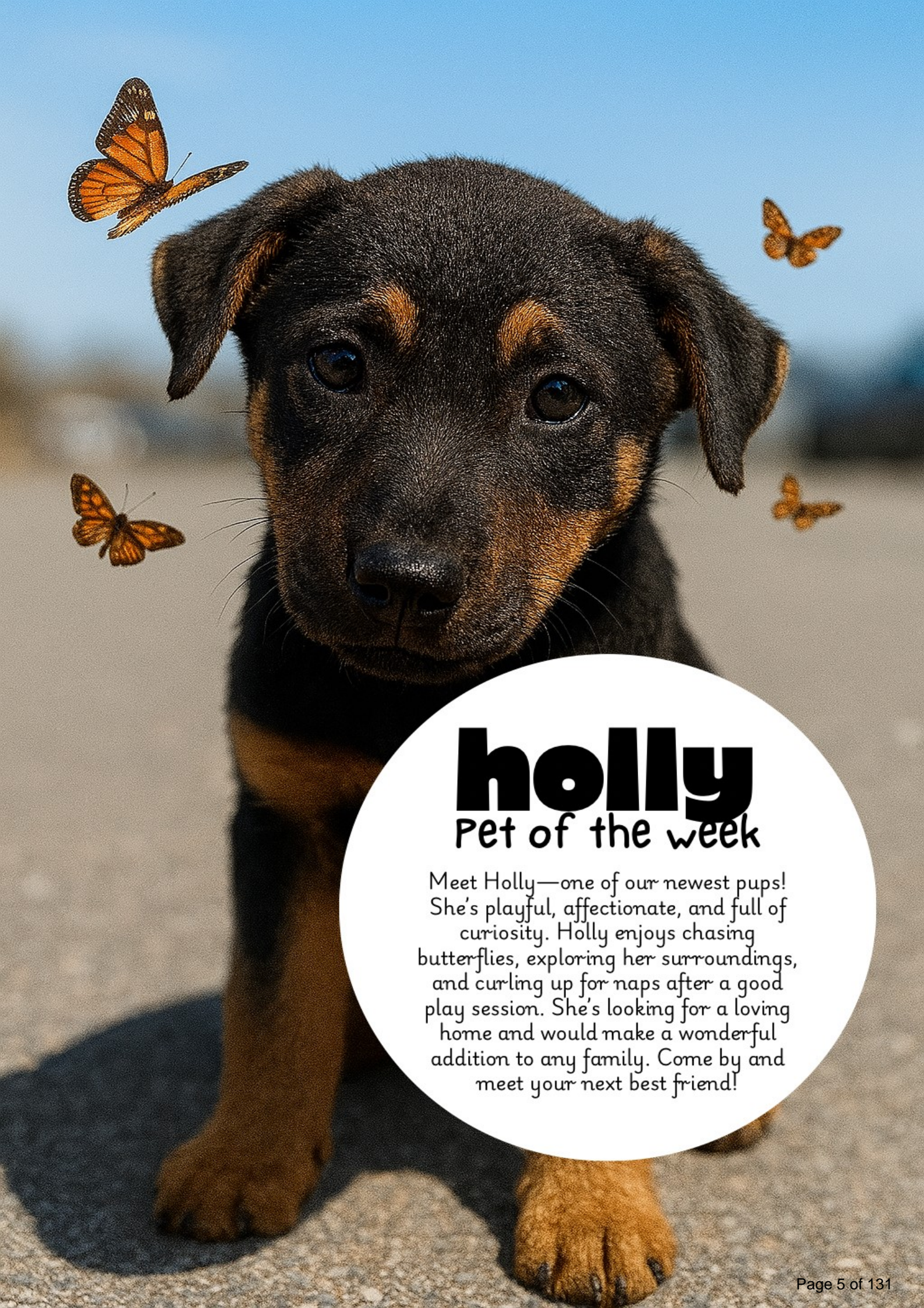

holly

Pet of the week

Meet Holly—one of our newest pups! She's playful, affectionate, and full of curiosity. Holly enjoys chasing butterflies, exploring her surroundings, and curling up for naps after a good play session. She's looking for a loving home and would make a wonderful addition to any family. Come by and meet your next best friend!



Expense Approval Report

By Vendor Name

Payment Dates 6/14/2025 - 6/27/2025

Vendor Name	Payable Number	Post Date	Description (Item)	Account Number	Amount
Vendor: ADLERHORST INT. - ADLERHORST INTERNATIONAL LLC					
ADLERHORST INTERNATIONAL...	Inv. 123147 - Training Patrol O...	06/24/2025	Inv. 123147 - Training Patrol O...	01-150-56000-0000-1	550.00
ADLERHORST INTERNATIONAL...	Inv. 123375 - K9 Monthly Off-S...	06/24/2025	Inv. 123375 - K9 Monthly Off-S...	01-150-56000-0000-1	292.00
Vendor ADLERHORST INT. - ADLERHORST INTERNATIONAL LLC Total:					842.00
Vendor: Advanced Data Storag - Advanced Data Storage, Inc.					
Advanced Data Storage, Inc.	Inv. 0206469 Service Console ...	06/16/2025	Inv. 0206469 Service Console ...	01-150-52200-0000-1	41.40
Advanced Data Storage, Inc.	INV0209133 First City Records...	06/16/2025	INV0209133 First City Records...	01-130-52200-0000-1	3,036.00
Vendor Advanced Data Storag - Advanced Data Storage, Inc. Total:					3,077.40
Vendor: Aerzen USA - Aerzen USA Corporation					
Aerzen USA Corporation	SEPI-25-002384 WWTP On-Sit...	06/16/2025	SEPI-25-002384 WWTP On-Sit...	30-500-56410-0000-1	3,400.00
Vendor Aerzen USA - Aerzen USA Corporation Total:					3,400.00
Vendor: ALBERTO MORALES III - ALBERTO MORALES III					
ALBERTO MORALES III	INV 7949 Paint Truck Steps 6/...	06/16/2025	INV 7949 Paint Truck Steps 6/...	01-180-56410-0000-1	1,266.00
ALBERTO MORALES III	INV 7621 A Water Dept. Cab L...	06/23/2025	INV 7621 A Water Dept. Cab L...	30-500-56600-0000-1	478.69
ALBERTO MORALES III	INV 7742A WWTP Roof Mnt Li...	06/23/2025	INV 7742A WWTP Roof Mnt Li...	30-500-56600-0000-1	554.67
Vendor ALBERTO MORALES III - ALBERTO MORALES III Total:					2,299.36
Vendor: Amazon Capital Servi - Amazon Capital Services, Inc.					
Amazon Capital Services, Inc.	INV 1P4W-TWCQ-9DMP Picke...	06/12/2025	INV 1P4W-TWCQ-9DMP Picke...	01-190-57400-0000-1	151.54
Amazon Capital Services, Inc.	Inv. 1VMF-YRCT-PKLN - Office ...	06/24/2025	Inv. 1VMF-YRCT-PKLN - Office ...	01-150-57200-0000-1	92.00
Amazon Capital Services, Inc.	Inv. 1WVW-RV67-9RF1 - Office ...	06/24/2025	Inv. 1WVW-RV67-9RF1 - Office ...	01-150-57200-0000-1	17.64
Vendor Amazon Capital Servi - Amazon Capital Services, Inc. Total:					261.18
Vendor: American Fidelity - American Fidelity					
American Fidelity	INV0030359	06/26/2025	American Fidelity Accident 1	01-22800-0000-1	19.34
American Fidelity	INV0030360	06/26/2025	Life 1	01-22900-0000-1	9.81
American Fidelity	INV0030361	06/26/2025	American Fidelity - Disability I...	01-22700-0000-1	129.49
American Fidelity	INV0030362	06/26/2025	Life 1	01-22900-0000-1	35.07
American Fidelity	INV0030363	06/26/2025	Life 2	01-22900-0000-1	24.00
American Fidelity	INV0030377	06/26/2025	Cancer 1 American Fidelity	01-22950-0000-1	13.53
Vendor American Fidelity - American Fidelity Total:					231.24
Vendor: American Office Solu - American Office Solutions, LLC					
American Office Solutions, LLC	INV 24888 Service Labor Agre...	06/16/2025	INV 24888 Service Labor Agre...	01-130-52200-0000-1	2,538.00
American Office Solutions, LLC	INV 24999 Public Works Yard ...	06/16/2025	INV 24999 Public Works Yard ...	01-310-52200-0000-1	29.56
American Office Solutions, LLC	INV 25000 City Hall Desk Phon...	06/16/2025	INV 25000 City Hall Desk Phon...	01-310-52200-0000-1	25.18
Vendor American Office Solu - American Office Solutions, LLC Total:					2,592.74
Vendor: Arredondo Automotive - Arredondo Automotive Group					
Arredondo Automotive Group	Inv. 303692 Unit 50 - Oil Chan...	06/23/2025	Inv. 303692 Unit 50 - Oil Chan...	01-150-56600-0000-1	122.98
Arredondo Automotive Group	INV 303441 GMC Sierra '22 R...	06/24/2025	INV 303441 GMC Sierra '22 R...	01-180-56600-0000-1	628.38
Vendor Arredondo Automotive - Arredondo Automotive Group Total:					751.36
Vendor: At&t Mobility - At&t Mobility					
At&t Mobility	AT&T June 2025 Monthly 287...	06/16/2025	AT&T June 2025 Monthly 287...	01-180-57800-0000-1	44.94
At&t Mobility	AT&T June 2025 Monthly 287...	06/16/2025	AT&T June 2025 Monthly 287...	20-200-57800-0000-1	8.98
At&t Mobility	AT&T June 2025 Monthly 287...	06/16/2025	AT&T June 2025 Monthly 287...	30-500-57800-0000-1	193.14
At&t Mobility	AT&T June 2025 Monthly 287...	06/16/2025	AT&T June 2025 Monthly 287...	32-510-57800-0000-1	188.10
At&t Mobility	AT&T June 2025 Monthly 287...	06/16/2025	AT&T June 2025 Monthly 287...	34-520-57800-0000-1	44.94
Vendor At&t Mobility - At&t Mobility Total:					480.10
Vendor: Auto Zone - Auto Zone					
Auto Zone	INV 06270112681 Transit Van ...	06/16/2025	INV 06270112681 Transit Van ...	34-520-56600-0000-1	44.59
Vendor Auto Zone - Auto Zone Total:					44.59
Vendor: bootbarn - Boot Barn					
Boot Barn	FY24-25 Boot Barn- Octavio R...	06/24/2025	FY24-25 Boot Barn- Octavio R...	32-510-51800-0000-1	194.84
Vendor bootbarn - Boot Barn Total:					194.84

Expense Approval Report

Payment Dates: 6/14/2025 - 6/27/2025

Vendor Name	Payable Number	Post Date	Description (Item)	Account Number	Amount
Vendor: CA Department of Jus - CA Department of Justice					
CA Department of Justice	Inv. 816473 Live Scan	06/23/2025	Inv. 809738 Live Scan - City Cl...	01-111-52200-0000-1	74.00
CA Department of Justice	Inv. 816473 Live Scan	06/23/2025	Inv. 816473 Live Scan - PD	01-150-56000-0000-1	243.00
Vendor CA Department of Jus - CA Department of Justice Total:					317.00
Vendor: CalPers - CalPers					
CalPers	Inv. 100000017628624	06/16/2025	Inv. 100000017628624	01-112-53200-0000-1	65.00
Vendor CalPers - CalPers Total:					65.00
Vendor: arcpoint labs of bak - Central California Testing Inc					
Central California Testing Inc	Inv. 0625285 On-Site Phlebot...	06/16/2025	Inv. 0625285 On-Site Phlebot...	01-150-56000-0000-1	293.60
Vendor arcpoint labs of bak - Central California Testing Inc Total:					293.60
Vendor: Cintas - Cintas Corporation No.3					
Cintas Corporation No.3	INV 4233005883 PW Laundry ...	06/23/2025	INV 4233005883 PW Laundry ...	01-180-51800-0000-1	166.40
Cintas Corporation No.3	INV 4233005883 PW Laundry ...	06/23/2025	INV 4233005883 PW Laundry ...	20-200-51800-0000-1	60.27
Cintas Corporation No.3	INV 4233005883 PW Laundry ...	06/23/2025	INV 4233005883 PW Laundry ...	30-500-51800-0000-1	158.42
Cintas Corporation No.3	INV 4233005883 PW Laundry ...	06/23/2025	INV 4233005883 PW Laundry ...	32-510-51800-0000-1	68.43
Cintas Corporation No.3	INV 4233005883 PW Laundry ...	06/23/2025	INV 4233005883 PW Laundry ...	34-520-51800-0000-1	10.11
Cintas Corporation No.3	INV 4233711630 PW Laundry ...	06/23/2025	INV 4233711630 PW Laundry ...	01-180-51800-0000-1	278.46
Cintas Corporation No.3	INV 4233711630 PW Laundry ...	06/23/2025	INV 4233711630 PW Laundry ...	20-200-51800-0000-1	88.59
Cintas Corporation No.3	INV 4233711630 PW Laundry ...	06/23/2025	INV 4233711630 PW Laundry ...	30-500-51800-0000-1	160.83
Cintas Corporation No.3	INV 4233711630 PW Laundry ...	06/23/2025	INV 4233711630 PW Laundry ...	32-510-51800-0000-1	69.45
Cintas Corporation No.3	INV 4233711630 PW Laundry ...	06/23/2025	INV 4233711630 PW Laundry ...	34-520-51800-0000-1	10.27
Cintas Corporation No.3	INV 4234480301 PW Laundry ...	06/23/2025	INV 4234480301 PW Laundry ...	01-180-51800-0000-1	170.80
Cintas Corporation No.3	INV 4234480301 PW Laundry ...	06/23/2025	INV 4234480301 PW Laundry ...	20-200-51800-0000-1	61.19
Cintas Corporation No.3	INV 4234480301 PW Laundry ...	06/23/2025	INV 4234480301 PW Laundry ...	30-500-51800-0000-1	156.83
Cintas Corporation No.3	INV 4234480301 PW Laundry ...	06/23/2025	INV 4234480301 PW Laundry ...	32-510-51800-0000-1	67.75
Cintas Corporation No.3	INV 4234480301 PW Laundry ...	06/23/2025	INV 4234480301 PW Laundry ...	34-520-51800-0000-1	14.64
Vendor Cintas - Cintas Corporation No.3 Total:					1,542.44
Vendor: CLA - CLIFTONLARSONALLEN LLP					
CLIFTONLARSONALLEN LLP	INV L251364403 ACFR Audit 6...	06/16/2025	INV L251364403 ACFR Audit 6...	01-130-56050-0000-1	682.50
CLIFTONLARSONALLEN LLP	INV L251364403 ACFR Audit 6...	06/16/2025	INV L251364403 ACFR Audit 6...	30-500-56050-0000-1	682.50
CLIFTONLARSONALLEN LLP	INV L251364403 ACFR Audit 6...	06/16/2025	INV L251364403 ACFR Audit 6...	31-505-56050-0000-1	315.00
CLIFTONLARSONALLEN LLP	INV L251364403 ACFR Audit 6...	06/16/2025	INV L251364403 ACFR Audit 6...	32-510-56050-0000-1	708.75
CLIFTONLARSONALLEN LLP	INV L251364403 ACFR Audit 6...	06/16/2025	INV L251364403 ACFR Audit 6...	34-520-56050-0000-1	236.25
Vendor CLA - CLIFTONLARSONALLEN LLP Total:					2,625.00
Vendor: College of The Sequo - College of The Sequoias Visalia					
College of The Sequoias Visalia	Ref 202520-05-9 Violet Ollag...	06/16/2025	Ref 202520-05-9 Laws of Arre...	01-150-52000-0000-1	159.00
College of The Sequoias Visalia	Ref 202520-05-9 Violet Ollag...	06/16/2025	Ref:202520-05-9 Laws of Arre...	01-165-52000-0000-1	159.00
Vendor College of The Sequo - College of The Sequoias Visalia Total:					318.00
Vendor: KCPW - County of Kern Public Works					
County of Kern Public Works	40975-CM	06/17/2025	INV 20212-IN Municipal Waste..	32-510-52200-0000-1	-148.83
County of Kern Public Works	INV 20212-IN Municipal Waste..	06/17/2025	INV 20212-IN Municipal Waste..	32-510-52200-0000-1	393.51
County of Kern Public Works	INV 49621-IN Green Waste/ O...	06/23/2025	INV 49621-IN Green Waste/ O...	01-180-52200-0000-1	363.54
Vendor KCPW - County of Kern Public Works Total:					608.22
Vendor: DACO FARM SUPPLY INC - DACO FARM SUPPLY INC					
DACO FARM SUPPLY INC	INV 390077 Services Charges ...	06/24/2025	INV 390077 Services Charges ...	30-500-53200-0000-1	30.84
Vendor DACO FARM SUPPLY INC - DACO FARM SUPPLY INC Total:					30.84
Vendor: Data Ticket, Inc - Data Ticket, Inc					
Data Ticket, Inc	Inv. 052025 Code Enforcement..	06/16/2025	Inv. 052025 Code Enforcement..	01-165-56000-0000-1	100.00
Data Ticket, Inc	Inv. 178865 Code Enforcement..	06/16/2025	Inv. 178865 Code Enforcement..	01-165-56000-0000-1	664.65
Data Ticket, Inc	Inv. 180057 - Citation Processi...	06/16/2025	Inv. 180057 - Citation Processi...	01-155-56000-0000-1	100.00
Vendor Data Ticket, Inc - Data Ticket, Inc Total:					864.65
Vendor: De Lage Landen - De Lage Landen Financial Services Inc					
De Lage Landen Financial Serv...	INV 590422605 07/01/2025 5...	06/16/2025	INV 590422605 07/01/2025 5...	01-130-52200-0000-1	117.99
De Lage Landen Financial Serv...	Inv. 590422296 06/07/2025 5...	06/24/2025	Inv. 590422296 06/07/2025 5...	01-150-52200-0000-1	113.66
De Lage Landen Financial Serv...	Inv. 590422694 6/06/2025 50...	06/24/2025	Inv. 590422694 6/06/2025 50...	01-150-52200-0000-1	160.26
Vendor De Lage Landen - De Lage Landen Financial Services Inc Total:					391.91

Expense Approval Report

Payment Dates: 6/14/2025 - 6/27/2025

Vendor Name	Payable Number	Post Date	Description (Item)	Account Number	Amount
Vendor: Dee Jaspar - Dee Jaspar & Associates, Inc					
Dee Jaspar & Associates, Inc	INV 25-00524 Operations & M...	06/12/2025	INV 25-00524 Operations & M...	32-510-56000-0000-1	359.70
Dee Jaspar & Associates, Inc	INV 24-00525 Elmo Well Proje...	06/16/2025	INV 24-00525 Elmo Well Proje...	32-510-52910-2313-1	3,315.82
Dee Jaspar & Associates, Inc	INV 25-00231R Tract 7394 Rei...	06/16/2025	INV 25-00231R Tract 7394 Rei...	01-140-56000-0000-1	2,284.00
Vendor Dee Jaspar - Dee Jaspar & Associates, Inc Total:					5,959.52
Vendor: Delano Veterinary - Delano Veterinary					
Delano Veterinary	Inv. 19654 Animal Cremation/...	06/24/2025	Inv. 19654 Animal Cremation/...	01-155-51100-0000-1	369.76
Delano Veterinary	Inv. 20938 Animal Cremation/...	06/24/2025	Inv. 20938 Animal Cremation/...	01-155-51100-0000-1	84.20
Vendor Delano Veterinary - Delano Veterinary Total:					453.96
Vendor: EDD - EDD					
EDD	INV0030380	06/26/2025	State Income Tax Withholding	01-22200-0000-1	3,380.99
EDD	INV0030381	06/26/2025	SDI - State Disability Insurance	01-22200-0000-1	1,114.87
EDD	INV0030382	06/26/2025	State Unemployment Insuran...	01-22250-0000-1	114.02
EDD	INV0030383	06/26/2025	Employment Training Tax	01-22275-0000-1	2.65
Vendor EDD - EDD Total:					4,612.53
Vendor: Edison - Edison					
Edison	Edison Acct 700468456995 B...	06/18/2025	Edison Acct 700468456995 B...	32-510-58000-0000-1	34,326.47
Vendor Edison - Edison Total:					34,326.47
Vendor: EFTPS - Electronic Federal Tax Payment System					
Electronic Federal Tax Paymen...	INV0030378	06/26/2025	Federal Income Tax Withholdi...	01-22050-0000-1	8,112.28
Electronic Federal Tax Paymen...	INV0030379	06/26/2025	Social Security	01-22100-0000-1	11,520.36
Electronic Federal Tax Paymen...	INV0030384	06/26/2025	Medicare	01-22150-0000-1	2,694.38
Vendor EFTPS - Electronic Federal Tax Payment System Total:					22,327.02
Vendor: EDIS - Employer Driven Insurance Services Inc					
Employer Driven Insurance Se...	INV0030292	06/16/2025	MBI EDIS 06/16/2025 Bank Dr...	01-115-50500-0000-1	46.65
Employer Driven Insurance Se...	INV0030292	06/16/2025	MBI EDIS 06/16/2025 Bank Dr...	30-500-50500-0000-1	46.66
Employer Driven Insurance Se...	INV0030292	06/16/2025	MBI EDIS 06/16/2025 Bank Dr...	31-505-50500-0000-1	15.55
Employer Driven Insurance Se...	INV0030292	06/16/2025	MBI EDIS 06/16/2025 Bank Dr...	32-510-50500-0000-1	46.65
Employer Driven Insurance Se...	INV0030296	06/16/2025	MBI EDIS 06/16/2025 Bank Dr...	01-115-50500-0000-1	15.15
Employer Driven Insurance Se...	INV0030296	06/16/2025	MBI EDIS 06/16/2025 Bank Dr...	01-150-50500-0000-1	50.00
Employer Driven Insurance Se...	INV0030296	06/16/2025	MBI EDIS 06/16/2025 Bank Dr...	30-500-50500-0000-1	15.16
Employer Driven Insurance Se...	INV0030296	06/16/2025	MBI EDIS 06/16/2025 Bank Dr...	31-505-50500-0000-1	5.05
Employer Driven Insurance Se...	INV0030296	06/16/2025	MBI EDIS 06/16/2025 Bank Dr...	32-510-50500-0000-1	15.15
Employer Driven Insurance Se...	INV0030300	06/16/2025	MBI EDIS 06/16/2025 Bank Dr...	01-115-50500-0000-1	3.76
Employer Driven Insurance Se...	INV0030300	06/16/2025	MBI EDIS 06/16/2025 Bank Dr...	01-180-50500-0000-1	6.04
Employer Driven Insurance Se...	INV0030300	06/16/2025	MBI EDIS 06/16/2025 Bank Dr...	20-200-50500-0000-1	0.19
Employer Driven Insurance Se...	INV0030300	06/16/2025	MBI EDIS 06/16/2025 Bank Dr...	30-500-50500-0000-1	3.75
Employer Driven Insurance Se...	INV0030300	06/16/2025	MBI EDIS 06/16/2025 Bank Dr...	31-505-50500-0000-1	1.25
Employer Driven Insurance Se...	INV0030300	06/16/2025	MBI EDIS 06/16/2025 Bank Dr...	32-510-50500-0000-1	3.76
Employer Driven Insurance Se...	INV0030418	06/23/2025	June 2025 EDIS Monthly Pay...	01-110-50500-0000-1	31.00
Employer Driven Insurance Se...	INV0030418	06/23/2025	June 2025 EDIS Monthly Pay...	01-111-50500-0000-1	19.60
Employer Driven Insurance Se...	INV0030418	06/23/2025	June 2025 EDIS Monthly Pay...	01-112-50500-0000-1	13.00
Employer Driven Insurance Se...	INV0030418	06/23/2025	June 2025 EDIS Monthly Pay...	01-115-50500-0000-1	40.80
Employer Driven Insurance Se...	INV0030418	06/23/2025	June 2025 EDIS Monthly Pay...	01-140-50500-0000-1	119.20
Employer Driven Insurance Se...	INV0030418	06/23/2025	June 2025 EDIS Monthly Pay...	01-150-50500-0000-1	688.50
Employer Driven Insurance Se...	INV0030418	06/23/2025	June 2025 EDIS Monthly Pay...	01-155-50500-0000-1	101.00
Employer Driven Insurance Se...	INV0030418	06/23/2025	June 2025 EDIS Monthly Pay...	01-160-50500-0000-1	10.40
Employer Driven Insurance Se...	INV0030418	06/23/2025	June 2025 EDIS Monthly Pay...	01-165-50500-0000-1	59.40
Employer Driven Insurance Se...	INV0030418	06/23/2025	June 2025 EDIS Monthly Pay...	01-175-50500-0000-1	13.00
Employer Driven Insurance Se...	INV0030418	06/23/2025	June 2025 EDIS Monthly Pay...	01-180-50500-0000-1	229.49
Employer Driven Insurance Se...	INV0030418	06/23/2025	June 2025 EDIS Monthly Pay...	01-190-50500-0000-1	49.00
Employer Driven Insurance Se...	INV0030418	06/23/2025	June 2025 EDIS Monthly Pay...	20-200-50500-0000-1	148.11
Employer Driven Insurance Se...	INV0030418	06/23/2025	June 2025 EDIS Monthly Pay...	30-500-50500-0000-1	396.59
Employer Driven Insurance Se...	INV0030418	06/23/2025	June 2025 EDIS Monthly Pay...	31-505-50500-0000-1	146.79
Employer Driven Insurance Se...	INV0030418	06/23/2025	June 2025 EDIS Monthly Pay...	32-510-50500-0000-1	309.12
Employer Driven Insurance Se...	INV0030418	06/23/2025	June 2025 EDIS Monthly Pay...	34-520-50500-0000-1	52.00
Vendor EDIS - Employer Driven Insurance Services Inc Total:					2,701.77

Expense Approval Report

Payment Dates: 6/14/2025 - 6/27/2025

Vendor Name	Payable Number	Post Date	Description (Item)	Account Number	Amount
Vendor: Ferguson Enterprises - Ferguson Enterprises					
Ferguson Enterprises	INV 0288488 WWTP Equip. R...	06/24/2025	INV 0288488 WWTP Equip. R...	30-500-56410-0000-1	1,873.21
Ferguson Enterprises	INV 0288489 WWTP Equip. R...	06/24/2025	INV 0288489 WWTP Equip. R...	30-500-56400-0000-1	1,488.16
Vendor Ferguson Enterprises - Ferguson Enterprises Total:					3,361.37
Vendor: ultrex managemen - Flex Print Intermediate LLC					
Flex Print Intermediate LLC	Inv. 4376726-CAL CN35796-01...	06/16/2025	Inv. 4376726-CAL CN35796-01...	01-150-52200-0000-1	62.66
Flex Print Intermediate LLC	Inv. 4392836-CAL CN33785-01...	06/16/2025	Inv. 4392836-CAL CN33785-01...	01-130-52200-0000-1	291.84
Flex Print Intermediate LLC	Inv. 4393805-CAL CN29305-01...	06/16/2025	Inv. 4393805-CAL CN29305-01...	01-150-52200-0000-1	274.18
Flex Print Intermediate LLC	Inv. 4400150-CAL CN35796-01...	06/24/2025	Inv. 4400150-CAL CN35796-01...	01-150-52200-0000-1	65.62
Vendor ultrex managemen - Flex Print Intermediate LLC Total:					694.30
Vendor: Fred C. Gilbert - Fred C. Gilbert					
Fred C. Gilbert	INV 313248 Materials Equip. ...	06/23/2025	INV 313248 Materials Equip. ...	32-510-56400-0000-1	404.60
Fred C. Gilbert	INV 313253 Water Dept Suppl...	06/23/2025	INV 313253 Water Dept Suppl...	32-510-56400-0000-1	163.51
Vendor Fred C. Gilbert - Fred C. Gilbert Total:					568.11
Vendor: Jason E Furgason - Furgason Electric Inc					
Furgason Electric Inc	INV 386-1 WWTP San Juan Lift...	06/16/2025	INV 386-1 WWTP San Juan Lift...	30-500-56410-0000-1	803.67
Furgason Electric Inc	INV 386-2 WWTP Hail Ln Lift S...	06/16/2025	INV 386-2 WWTP Hail Ln Lift S...	30-500-56410-0000-1	694.45
Vendor Jason E Furgason - Furgason Electric Inc Total:					1,498.12
Vendor: Granite Auto Parts I - Granite Auto Parts Inc					
Granite Auto Parts Inc	INV 857673 Water Dept.Suppl...	06/16/2025	INV 857673 Water Dept.Suppl...	32-510-57400-0000-1	65.43
Granite Auto Parts Inc	INV 857727 Water Nipple 5/3...	06/16/2025	INV 857727 Water Nipple 5/3...	32-510-57400-0000-1	42.49
Granite Auto Parts Inc	INV 858068 LLMD Mowing H...	06/16/2025	INV 858068 LLMD Mowing H...	20-200-56700-0000-1	33.55
Granite Auto Parts Inc	INV 858143 WWTP Cleaning S...	06/16/2025	INV 858143 WWTP Cleaning S...	30-500-57400-0000-1	449.06
Granite Auto Parts Inc	INV 858276 WWTP Supplies 6...	06/16/2025	INV 858276 WWTP Supplies 6...	30-500-56600-0000-1	82.71
Granite Auto Parts Inc	INV 858277 LLMD Supplies 6/...	06/16/2025	INV 858277 LLMD Supplies 6/...	20-200-57400-0000-1	8.65
Granite Auto Parts Inc	INV 858363 Streets Dept. Mot...	06/16/2025	INV 858363 Streets Dept. Mot...	01-180-56600-0000-1	87.04
Granite Auto Parts Inc	INV 857963 Water Dept. Oil &...	06/23/2025	INV 857963 Water Dept. Oil &...	30-500-56600-0000-1	57.20
Granite Auto Parts Inc	INV 85837 Water Supplies 6/2...	06/23/2025	INV 85837 Water Supplies 6/2...	32-510-57400-0000-1	23.76
Granite Auto Parts Inc	INV 858373 WWTP Supplies 6...	06/23/2025	INV 858373 WWTP Supplies 6...	30-500-56600-0000-1	136.36
Granite Auto Parts Inc	INV 858377 Water Dept. Suppl..	06/23/2025	INV 858377 Water Dept. Suppl..	32-510-56600-0000-1	38.97
Granite Auto Parts Inc	INV 858459 Water Dept. Suppl..	06/23/2025	INV 858459 Water Dept. Suppl..	32-510-56600-0000-1	47.01
Granite Auto Parts Inc	INV 858548 LLMD Supplies 6/...	06/23/2025	INV 858548 LLMD Supplies 6/...	20-200-57400-0000-1	32.46
Granite Auto Parts Inc	INV 858587 Street Dept. Head...	06/23/2025	INV 858587 Street Dept. Head...	01-180-57400-0000-1	21.63
Granite Auto Parts Inc	INV 858644 Water Dept. Suppl..	06/24/2025	INV 858644 Water Dept. Suppl..	32-510-57400-0000-1	25.16
Granite Auto Parts Inc	INV 858645 Streets Dept. Fuse...	06/24/2025	INV 858645 Streets Dept. Fuse...	01-180-56500-0000-1	5.13
Vendor Granite Auto Parts I - Granite Auto Parts Inc Total:					1,156.61
Vendor: Gregs Petroleum - Gregs Petroleum					
Gregs Petroleum	Fuel INV 544094 06/10/25	06/16/2025	Fuel INV 544094 06/10/25	01-150-54000-0000-1	1,603.87
Gregs Petroleum	Fuel INV 545677 6/13/25	06/24/2025	Fuel INV 545677 6/13/25	01-150-54000-0000-1	1,671.85
Gregs Petroleum	Fuel INV 546215 6/17/25	06/24/2025	Fuel INV 546215 6/17/25	01-150-54000-0000-1	1,568.41
Gregs Petroleum	Fuel INV 547093 6/20/25	06/24/2025	Fuel INV 547093 6/20/25	01-150-54000-0000-1	1,043.05
Vendor Gregs Petroleum - Gregs Petroleum Total:					5,887.18
Vendor: Herc Rentals Inc - Herc Rentals Inc					
Herc Rentals Inc	INV 35545255-001 Skidsteer B...	06/24/2025	INV 35545255-001 Skidsteer B...	30-500-53800-0000-1	2,138.41
Vendor Herc Rentals Inc - Herc Rentals Inc Total:					2,138.41
Vendor: Hodges - Hodges Law Group					
Hodges Law Group	INV 00628 Legal Services 6/1/...	06/24/2025	City Council Legal Service	01-130-56100-0000-1	1,970.50
Hodges Law Group	INV 00628 Legal Services 6/1/...	06/24/2025	Community Development Lega...	01-130-56100-0000-1	1,493.50
Hodges Law Group	INV 00628 Legal Services 6/1/...	06/24/2025	Human Resources Legal Service	01-130-56100-0000-1	988.00
Hodges Law Group	INV 00628 Legal Services 6/1/...	06/24/2025	Contractual Retainer Legal Ser...	01-130-56100-0000-1	342.00
Hodges Law Group	INV 00628 Legal Services 6/1/...	06/24/2025	Legal Service Reimbursable	01-130-56100-0000-1	247.00
Hodges Law Group	INV 00628 Legal Services 6/1/...	06/24/2025	Admin Legal Service	01-130-56100-0000-1	4,773.50
Vendor Hodges - Hodges Law Group Total:					9,814.50
Vendor: Home Depot - Home Depot					
Home Depot	Inv. 7904096 - Ford Key	06/23/2025	Inv. 7904096 - Ford Key	01-150-56000-0000-1	10.76
Home Depot	Inv. 8902259 - 17 Gal Storage ...	06/23/2025	Inv. 8902259 - 17 Gal Storage ...	01-150-57200-0000-1	10.26
Home Depot	Inv. 904489 - Brass Key	06/23/2025	Inv. 904489 - Brass Key	01-150-56000-0000-1	12.93
Home Depot	INV 1090454 Water Dept. Equ...	06/24/2025	INV 1090454 Water Dept. Equ...	32-510-56400-0000-1	74.51

Expense Approval Report

Payment Dates: 6/14/2025 - 6/27/2025

Vendor Name	Payable Number	Post Date	Description (Item)	Account Number	Amount
Home Depot	INV 2901288 Facilities Maint. ...	06/25/2025	INV 2901288 Facilities Maint. ...	01-190-57400-0000-1	57.70
Home Depot	INV 3532398 Streets Dept. Su...	06/24/2025	INV 3532398 Streets Dept. Su...	01-180-57400-0000-1	62.41
Home Depot	INV 531817 Streets Supplies 5...	06/25/2025	INV 531817 Streets Supplies 5...	01-180-57400-0000-1	186.31
Home Depot	INV 5901802 WWTP Supplies ...	06/25/2025	INV 5901802 WWTP Supplies ...	30-500-56400-0000-1	177.02
Home Depot	INV 6510121 Streets Dept. Su...	06/24/2025	INV 6510121 Streets Dept. Su...	01-180-56500-0000-1	37.52
Home Depot	INV 6901672 City Hall Repair 6...	06/25/2025	INV 6901672 City Hall Repair 6...	01-190-57400-0000-1	24.09
Home Depot	INV 7901609 Food Truck Suppl..	06/25/2025	INV 7901609 Food Truck Suppl..	01-190-57400-0000-1	177.80
Home Depot	INV 7902315 Facilities Main. S...	06/24/2025	INV 7902315 Facilities Main. S...	01-190-56800-0000-1	221.93
Home Depot	INV 8901521 WWTP Supplies ...	06/25/2025	INV 8901521 WWTP Supplies ...	30-500-57400-0000-1	122.64
Home Depot	INV 8902238 Streets Dept. Su...	06/24/2025	INV 8902238 Streets Dept. Su...	01-180-57400-0000-1	56.24
Home Depot	INV 902694 6/20/25	06/25/2025	INV 902694 6/20/25	01-180-57400-0000-1	8.10
Home Depot	Inv. 1031281 Ops Supplies	06/24/2025	Inv. 1031281 Ops Supplies	01-165-57400-0000-1	125.35
Home Depot	INV99514439 Streets Dept. 5/...	06/24/2025	INV99514439	01-180-57400-0000-1	22.17
Vendor Home Depot - Home Depot Total:					1,387.74

Vendor: Irrigation Concepts - Irrigation Concepts

Irrigation Concepts	INV 50068 LLMD Operating Su...	06/16/2025	INV 50068 LLMD Operating Su...	20-200-57400-0000-1	22.97
Irrigation Concepts	INV 50127 Streets Supplies 6/...	06/19/2025	INV 50127 Streets Supplies 6/...	01-180-57400-0000-1	202.62
Irrigation Concepts	INV 50127 Streets Supplies 6/...	06/19/2025	INV 50127 Streets Supplies 6/...	01-190-57400-0000-1	54.86
Irrigation Concepts	INV 50070 Browning Rd Park ...	06/23/2025	INV 50070 Browning Rd Park ...	32-510-52200-0000-1	450.00
Irrigation Concepts	INV 50138 LLMD Blanco Park ...	06/24/2025	INV 50138 LLMD Blanco Park ...	20-200-57400-0000-1	1.62
Vendor Irrigation Concepts - Irrigation Concepts Total:					732.07

Vendor: JC Concrete Construc - JC Concrete Construction Inc.

JC Concrete Construction Inc.	INV 1056 WWTP Excavation& ...	06/16/2025	INV 1056 WWTP Excavation& ...	30-500-56400-0000-1	2,050.00
JC Concrete Construction Inc.	INV 1059 Blanco Park Lighting...	06/16/2025	INV 1059 Blanco Park Lighting...	20-200-52200-0000-1	3,100.00
Vendor JC Concrete Construc - JC Concrete Construction Inc. Total:					5,150.00

Vendor: Jim Burke - Jim Burke

Jim Burke	Inv.269901 Unit 41 Check Eng...	06/16/2025	Inv.269901 Unit 41 Check Eng...	01-150-56600-0000-1	1,305.85
Jim Burke	Inv.276702 Unit 57 Engine Oil...	06/16/2025	Inv.276702 Unit 57 Engine Oil...	01-150-56600-0000-1	100.63
Vendor Jim Burke - Jim Burke Total:					1,406.48

Vendor: Joel Lopez - Joel Lopez

Joel Lopez	INV 0090 McFar USA Run - Joel..	06/16/2025	INV 0090 McFar USA Run - Joel..	01-24600-8207-1	500.00
Vendor Joel Lopez - Joel Lopez Total:					500.00

Vendor: John Hancock - John Hancock

John Hancock	INV0030357	06/26/2025	401K - Employer	01-20800-0000-1	5,080.13
John Hancock	INV0030358	06/26/2025	401K - Employee	01-20800-0000-1	3,963.25
John Hancock	INV0030365	06/26/2025	401K Loan 1	01-20800-0000-1	89.29
John Hancock	INV0030366	06/26/2025	401K Loan 1	01-20800-0000-1	112.59
John Hancock	INV0030367	06/26/2025	401K Loan 1	01-20800-0000-1	159.86
John Hancock	INV0030368	06/26/2025	401K Loan 1	01-20800-0000-1	256.31
John Hancock	INV0030369	06/26/2025	401K Loan 1	01-20800-0000-1	107.12
John Hancock	INV0030370	06/26/2025	401k Contribution	01-20800-0000-1	322.73
John Hancock	INV0030371	06/26/2025	401k Contribution	01-20800-0000-1	370.12
John Hancock	INV0030372	06/26/2025	401k Contribution	01-20800-0000-1	304.67
John Hancock	INV0030373	06/26/2025	401k Contribution	01-20800-0000-1	259.72
John Hancock	INV0030374	06/26/2025	401k Contribution	01-20800-0000-1	675.00
John Hancock	INV0030375	06/26/2025	401k Contribution	01-20800-0000-1	295.44
John Hancock	INV0030376	06/26/2025	401k Contribution	01-20800-0000-1	800.00
Vendor John Hancock - John Hancock Total:					12,796.23

Vendor: J's Automotive - J's Automotive

J's Automotive	INV 10027 Transit Toy. Sienna...	06/23/2025	INV 10027 Transit Toy. Sienna...	34-520-56600-0000-1	65.00
J's Automotive	INV 10036 Transit Toyota Van...	06/24/2025	INV 10036 Transit Toyota Van...	34-520-56600-0000-1	160.14
Vendor J's Automotive - J's Automotive Total:					225.14

Vendor: Munguia - Juan Munguia

Juan Munguia	Inv. I-8462-1 Service Call - PD ...	06/16/2025	Inv. I-8462-1 Service Call - PD ...	01-150-56400-0000-1	950.00
Juan Munguia	INV-8472-1 Veteran's Hall Mai...	06/23/2025	INV-8472-1 Veteran's Hall Mai...	01-185-56400-0000-1	809.91
Juan Munguia	Inv. I-8532-1 Service Call - PD ...	06/24/2025	Inv. I-8532-1 Service Call - PD ...	01-150-56400-0000-1	335.00
Vendor Munguia - Juan Munguia Total:					2,094.91

Expense Approval Report

Payment Dates: 6/14/2025 - 6/27/2025

Vendor Name	Payable Number	Post Date	Description (Item)	Account Number	Amount
Vendor: Kern County Forensic - Kern County Forensic Services, LLC					
Kern County Forensic Services,...	Inv. 3060 Case #25-00426 (06...	06/16/2025	Inv. 3060 Case #25-00426 (06...	01-150-56000-0000-1	1,500.00
Vendor Kern County Forensic - Kern County Forensic Services, LLC Total:					1,500.00
Vendor: KOEFRAN - Koefran Industries, Inc.					
Koefran Industries, Inc.	Inv. 0000660316 Monthly Serv..	06/16/2025	Inv. 0000660316 Monthly Serv..	01-155-51100-0000-1	220.50
Vendor KOEFRAN - Koefran Industries, Inc. Total:					220.50
Vendor: lezly m magallanes - Lezly M Magallanes					
Lezly M Magallanes	FY24-25 GEO Scholarship DE 6...	06/16/2025	FY24-25 GEO Scholarship DE 6...	01-105-57100-2502-1	300.00
Vendor lezly m magallanes - Lezly M Magallanes Total:					300.00
Vendor: lowes home centers - Lowes Companies INC					
Lowes Companies INC	INV 974240-PCAGGM Mujers ...	06/19/2025	INV 974240-PCAGGM Mujers ...	01-180-57400-0000-1	292.79
Vendor lowes home centers - Lowes Companies INC Total:					292.79
Vendor: McFarland POA - McFarland Police Officers Association					
McFarland Police Officers Ass...	INV0030364	06/26/2025	Association Dues	01-20200-0000-1	960.00
Vendor McFarland POA - McFarland Police Officers Association Total:					960.00
Vendor: McFarland Tire - McFarland Tire					
McFarland Tire	INV 37434 Water TruckTire Pa...	06/16/2025	INV 37434 Water TruckTire Pa...	30-500-56600-0000-1	45.00
McFarland Tire	Inv. 38206 Fix Flat Tire & TPMS..	06/16/2025	Inv. 38206 Fix Flat Tire & TPMS..	01-165-56600-0000-1	110.00
Vendor McFarland Tire - McFarland Tire Total:					155.00
Vendor: Harbor Freight - Multi Service Technology Solutions, Inc					
Multi Service Technology Solut..	INV 7fa04eab WWTP Welding...	06/19/2025	INV 7fa04eab WWTP Welding...	30-500-56410-0000-1	194.67
Multi Service Technology Solut..	INV afb0f27a WWTP Ring ATV...	06/23/2025	INV afb0f27a WWTP Ring ATV...	30-500-56600-0000-1	24.85
Vendor Harbor Freight - Multi Service Technology Solutions, Inc Total:					219.52
Vendor: MVP Sanitation - MVP Sanitation					
MVP Sanitation	Inv. 000097535 Standard Port...	06/24/2025	Inv. 000097535 Standard Port...	01-150-56000-0000-1	215.00
Vendor MVP Sanitation - MVP Sanitation Total:					215.00
Vendor: Odilon Gomez - Odilon Gomez					
Odilon Gomez	Veteran's Hall Rental Deposit ...	06/24/2025	Veteran's Hall Rental Deposit ...	01-24000-0000-1	350.00
Vendor Odilon Gomez - Odilon Gomez Total:					350.00
Vendor: Office Depot - Office Depot					
Office Depot	INV 419732090001 Finance Of...	06/16/2025	INV 419732090001 Finance Of...	01-115-57200-0000-1	37.13
Office Depot	INV 419732090001 Finance Of...	06/16/2025	INV 419732090001 Finance Of...	30-500-57200-0000-1	37.13
Office Depot	INV 419732090001 Finance Of...	06/16/2025	INV 419732090001 Finance Of...	31-505-57200-0000-1	37.13
Office Depot	INV 419732090001 Finance Of...	06/16/2025	INV 419732090001 Finance Of...	32-510-57200-0000-1	37.13
Vendor Office Depot - Office Depot Total:					148.52
Vendor: PG&E COMPANY - PG&E COMPANY					
PG&E COMPANY	PG&E June2025 Monthly Billin...	06/24/2025	4022268837-2	01-180-58000-0000-1	155.67
PG&E COMPANY	PG&E June2025 Monthly Billin...	06/24/2025	0891499733-6	01-180-58000-0000-1	78.47
PG&E COMPANY	PG&E June2025 Monthly Billin...	06/24/2025	7576987527-1	01-180-58000-0000-1	363.72
PG&E COMPANY	PG&E June2025 Monthly Billin...	06/24/2025	4453174177-3	01-180-58000-0000-1	930.70
PG&E COMPANY	PG&E June2025 Monthly Billin...	06/24/2025	2012021553-6	01-180-58100-0000-1	1,106.72
PG&E COMPANY	PG&E June2025 Monthly Billin...	06/24/2025	0741726506-8	01-180-58100-0000-1	550.23
PG&E COMPANY	PG&E June2025 Monthly Billin...	06/24/2025	6094933730-1	01-180-58100-0000-1	227.32
PG&E COMPANY	PG&E June2025 Monthly Billin...	06/24/2025	1601672325-2	01-180-58100-0000-1	301.89
PG&E COMPANY	PG&E June2025 Monthly Billin...	06/24/2025	7663752590-8	01-180-58100-0000-1	26.65
PG&E COMPANY	PG&E June2025 Monthly Billin...	06/24/2025	5629608181-5	01-180-58100-0000-1	29.77
PG&E COMPANY	PG&E June2025 Monthly Billin...	06/24/2025	4483764300-4	01-180-58100-0000-1	54.06
PG&E COMPANY	PG&E June2025 Monthly Billin...	06/24/2025	356448726-8	01-180-58100-0000-1	59.84
PG&E COMPANY	PG&E June2025 Monthly Billin...	06/24/2025	5568620890-5	01-180-58100-0000-1	10.47
PG&E COMPANY	PG&E June2025 Monthly Billin...	06/24/2025	3877090180-9	01-180-58100-0000-1	458.47
PG&E COMPANY	PG&E June2025 Monthly Billin...	06/24/2025	4191871709-5	01-185-58000-0000-1	1,648.66
PG&E COMPANY	PG&E June2025 Monthly Billin...	06/24/2025	7668473786-9	01-190-58000-0000-1	3,544.10
PG&E COMPANY	PG&E June2025 Monthly Billin...	06/24/2025	7336692458-4	20-200-58100-0000-1	1,610.12
PG&E COMPANY	PG&E June2025 Monthly Billin...	06/24/2025	6372122228-7	20-200-58100-0000-1	804.58
PG&E COMPANY	PG&E June2025 Monthly Billin...	06/24/2025	5794429226-7	20-200-58100-0000-1	249.42
PG&E COMPANY	PG&E June2025 Monthly Billin...	06/24/2025	0309941756-4	20-200-58100-0000-1	260.55
PG&E COMPANY	PG&E June2025 Monthly Billin...	06/24/2025	0979037755-1	20-200-58100-0000-1	43.61

Expense Approval Report

Payment Dates: 6/14/2025 - 6/27/2025

Vendor Name	Payable Number	Post Date	Description (Item)	Account Number	Amount
PG&E COMPANY	PG&E June2025 Monthly Billin...	06/24/2025	3047362805-2	20-200-58100-0000-1	179.24
PG&E COMPANY	PG&E June2025 Monthly Billin...	06/24/2025	5842445837-8	30-500-58000-0000-1	258.05
PG&E COMPANY	PG&E June2025 Monthly Billin...	06/24/2025	9048125100-8	30-500-58000-0000-1	183.28
PG&E COMPANY	PG&E June2025 Monthly Billin...	06/24/2025	0843084856-7	32-510-58000-0000-1	366.08
PG&E COMPANY	PG&E June2025 Monthly Billin...	06/24/2025	2687153110-4	32-510-58000-0000-1	26,465.80
PG&E COMPANY	PG&E June2025 Monthly Billin...	06/24/2025	0425382282-1	32-510-58000-0000-1	148.39
PG&E COMPANY	PG&E June2025 Monthly Billin...	06/24/2025	6395880662-0	32-510-58000-0000-1	20.84
PG&E COMPANY	PG&E June2025 Monthly Billin...	06/24/2025	7699604118-2	32-510-58000-0000-1	4,331.97

Vendor PG&E COMPANY - PG&E COMPANY Total: 44,468.67

Vendor: radiotronics - Radiotronics Inc

Radiotronics Inc	Inv. 297060 Ace Watch Dog Se...	06/16/2025	Inv. 297060 Ace Watch Dog Se...	01-150-56000-0000-1	168.00
------------------	---------------------------------	------------	---------------------------------	---------------------	--------

Vendor radiotronics - Radiotronics Inc Total: 168.00

Vendor: RAMIRO SANTIVANES - RAMIRO SANTIVANES

RAMIRO SANTIVANES	INV 3179 Temp. Fence Rental ...	06/19/2025	INV 3179 Temp. Fence Rental ...	01-190-56800-0000-1	900.00
-------------------	---------------------------------	------------	---------------------------------	---------------------	--------

Vendor RAMIRO SANTIVANES - RAMIRO SANTIVANES Total: 900.00

Vendor: artias collision c - Reuben Artiaga

Reuben Artiaga	Inv. 25610 Unit 51 Refinish D...	06/16/2025	Inv. 25610 Unit 51 Refinish D...	01-150-52940-0000-1	1,934.86
----------------	----------------------------------	------------	----------------------------------	---------------------	----------

Vendor artias collision c - Reuben Artiaga Total: 1,934.86

Vendor: PLATT - Rexel USA Supply

Rexel USA Supply	INV 6173161 Food Truck 6/6/25	06/16/2025	INV 6173161 Food Truck 6/6/25	01-190-57400-0000-1	831.96
Rexel USA Supply	INV 6184063 Blanco Park 6/10...	06/16/2025	INV 6184063 Blanco Park 6/10...	20-200-57400-0000-1	62.94
Rexel USA Supply	INV 6J02072 Food Truck Electr...	06/19/2025	INV 6J02072 Food Truck Electr...	01-190-57400-0000-1	219.88
Rexel USA Supply	INV 6I35059 Frontage Propert...	06/23/2025	INV 6I35059 Frontage Propert...	01-190-56400-0000-1	892.47
Rexel USA Supply	INV 6I35085 Frontage Propert...	06/23/2025	INV 6I35085 Frontage Propert...	01-190-57400-0000-1	691.13
Rexel USA Supply	INV 6J08925 Food Truck Electr...	06/23/2025	INV 6J08925 Food Truck Electr...	01-190-56400-0000-1	66.77
Rexel USA Supply	INV 6J09657 Frontage Propert...	06/23/2025	INV 6J09657 Frontage Propert...	01-190-56400-0000-1	198.89
Rexel USA Supply	INV 6J23775 Food Truck Electr...	06/23/2025	INV 6J23775 Food Truck Electr...	01-190-56400-0000-1	440.04
Rexel USA Supply	INV 9Z85130 City Hall Facilit ...	06/23/2025	INV 9Z85130 City Hall Facilit ...	01-190-56400-0000-1	55.24
Rexel USA Supply	INV 9Z93248 Food Truck Suppl..	06/24/2025	INV 9Z93248 Food Truck Suppl..	01-190-56400-0000-1	371.60

Vendor PLATT - Rexel USA Supply Total: 3,830.92

Vendor: SC SITES Services - SC SITES Services

SC SITES Services	Inv. 52152 Repeater Rental A...	06/16/2025	Inv. 52152 Repeater Rental A...	01-150-52200-0000-1	1,698.00
-------------------	---------------------------------	------------	---------------------------------	---------------------	----------

Vendor SC SITES Services - SC SITES Services Total: 1,698.00

Vendor: Serdas - Serdas Plumbing Inc

Serdas Plumbing Inc	Inv 3000453 Animal Shelter K...	06/16/2025	Inv 3000453 Animal Shelter K...	01-155-56000-0000-1	494.40
---------------------	---------------------------------	------------	---------------------------------	---------------------	--------

Vendor Serdas - Serdas Plumbing Inc Total: 494.40

Vendor: SPD - SPD

SPD	Inv. 4892 Decals - Unit 51	06/16/2025	Inv. 4892 Decals - Unit 51	01-150-52940-0000-1	389.70
-----	----------------------------	------------	----------------------------	---------------------	--------

Vendor SPD - SPD Total: 389.70

Vendor: stephanie ramirez be - Stephanie Ramirez Becerra

Stephanie Ramirez Becerra	FY24-25 GEO Scholarship DE 6...	06/16/2025	FY24-25 GEO Scholarship DE 6...	01-105-57100-2502-1	300.00
---------------------------	---------------------------------	------------	---------------------------------	---------------------	--------

Vendor stephanie ramirez be - Stephanie Ramirez Becerra Total: 300.00

Vendor: Stinson Stationers, - Stinson Stationers, Inc.

Stinson Stationers, Inc.	Inv. 335841-0 Office Supplies	06/24/2025	Inv. 335841-0 Office Supplies	01-150-57200-0000-1	91.86
--------------------------	-------------------------------	------------	-------------------------------	---------------------	-------

Vendor Stinson Stationers, - Stinson Stationers, Inc. Total: 91.86

Vendor: SunRise - SunRise

SunRise	INV 1539030 Aerosols 5/27/25	06/23/2025	INV 1539030 Aerosols 5/27/25	01-180-57400-0000-1	232.18
SunRise	INV 1539030 Aerosols 5/27/25	06/23/2025	INV 1539030 Aerosols 5/27/25	20-200-57400-0000-1	232.18

Vendor SunRise - SunRise Total: 464.36

Vendor: Bakersfield Cal. - The Bakersfield Californian

The Bakersfield Californian	INV 481676 2025 Street Rehab..	06/25/2025	INV 481676 2025 Street Rehab..	25-000-52960-2401-1	680.24
-----------------------------	--------------------------------	------------	--------------------------------	---------------------	--------

Vendor Bakersfield Cal. - The Bakersfield Californian Total: 680.24

Vendor: The Print Shop Inc. - The Print Shop Inc.

The Print Shop Inc.	INV 1748 The Print Shop- McF...	06/24/2025	INV 1748 The Print Shop- McF...	01-105-51800-0000-1	518.36
---------------------	---------------------------------	------------	---------------------------------	---------------------	--------

Vendor The Print Shop Inc. - The Print Shop Inc. Total: 518.36

Expense Approval Report

Payment Dates: 6/14/2025 - 6/27/2025

Vendor Name	Payable Number	Post Date	Description (Item)	Account Number	Amount
Vendor: Trinity Safety Compa - Trinity Safety Company					
Trinity Safety Company	INV 232309 Gloves & Coveralls..	06/12/2025	INV 232309 Gloves & Coveralls..	32-510-56410-0000-1	359.39
Trinity Safety Company	INV 232595 WWTP Safety Equ...	06/16/2025	INV 232595 WWTP Safety Equ...	30-500-57400-0000-1	119.08
Trinity Safety Company	INV 232596 Streets Safety Equ...	06/23/2025	INV 232596 Streets Safety Equ...	01-180-56800-0000-1	142.89
Vendor Trinity Safety Compa - Trinity Safety Company Total:					621.36
Vendor: ULINE - ULINE					
ULINE	INV 193263724 WWTP Picnic ...	06/19/2025	INV 193263724 WWTP Picnic ...	30-500-57400-0000-1	818.24
Vendor ULINE - ULINE Total:					818.24
Vendor: USA Waste of Califor - USA Waste of California, Inc.					
USA Waste of California, Inc.	May 2025 Waste Management..	06/18/2025	May 2025 Waste Management..	01-100-41300-0000-1	-1,505.95
USA Waste of California, Inc.	May 2025 Waste Management..	06/18/2025	May 2025 Waste Management..	01-100-41300-0000-1	-279.18
USA Waste of California, Inc.	May 2025 Waste Management..	06/18/2025	May 2025 Waste Management..	01-100-41300-0000-1	-4,283.79
USA Waste of California, Inc.	May 2025 Waste Management..	06/18/2025	May 2025 Waste Management..	31-505-52400-0000-1	85,675.73
USA Waste of California, Inc.	May 2025 Waste Management..	06/18/2025	May 2025 Waste Management..	31-505-52500-0000-1	2,791.83
USA Waste of California, Inc.	May 2025 Waste Management..	06/18/2025	May 2025 Waste Management..	31-505-52500-0000-1	15,059.52
Vendor USA Waste of Califor - USA Waste of California, Inc. Total:					97,458.16
Vendor: Valley Psychological - Valley Psychological Group					
Valley Psychological Group	Psych Evaluation - LOP-ES	06/16/2025	Psych Evaluation - LOP-ES	01-150-56000-0000-1	400.00
Vendor Valley Psychological - Valley Psychological Group Total:					400.00
Vendor: BAR100 - Vanessa Barron					
Vanessa Barron	Reimbursement -Meals & IE -S...	06/17/2025	Reimbursement -Meals & IE -S...	01-150-52000-0000-1	473.00
Vendor BAR100 - Vanessa Barron Total:					473.00
Vendor: Vernon C. Sorenson - Vernon C. Sorenson					
Vernon C. Sorenson	Inv. 00575484-00 (Esteban Lo...	06/16/2025	Inv. 00575484-00 (Esteban Lo...	01-150-56000-0000-1	652.00
Vernon C. Sorenson	Inv. 00575519-00 (Jose Navar...	06/16/2025	Inv. 00575519-00 (Jose Navar...	01-150-56000-0000-1	652.00
Vernon C. Sorenson	INV. 00575565-00- Maria Espa...	06/16/2025	INV. 00575565-00- Maria Espa...	01-150-56000-0000-1	215.00
Vernon C. Sorenson	INV. 00576828-00 Destiny Per...	06/16/2025	INV. 00576828-00 Destiny Per...	01-150-56000-0000-1	215.00
Vendor Vernon C. Sorenson - Vernon C. Sorenson Total:					1,734.00
Vendor: Visual Edge - Visual Edge IT, Inc.					
Visual Edge IT, Inc.	INV 24AR2726332 Monthly C...	06/16/2025	INV 24AR2726332 Monthly C...	01-130-54800-0000-1	79.16
Visual Edge IT, Inc.	INV 24AR2746967 Monthly C...	06/24/2025	INV 24AR2746967 Monthly C...	01-130-54800-0000-1	500.73
Vendor Visual Edge - Visual Edge IT, Inc. Total:					579.89
Vendor: WestAir - WestAir Gases & Equipment, Inc.					
WestAir Gases & Equipment, I...	INV 0011992733 Street and ...	06/16/2025	INV 0011992733 Street and ...	01-180-57400-0000-1	485.64
WestAir Gases & Equipment, I...	INV 0011992733 Street and ...	06/16/2025	INV 0011992733 Street and ...	20-200-57400-0000-1	485.64
Vendor WestAir - WestAir Gases & Equipment, Inc. Total:					971.28
Grand Total:					304,380.54

Report Summary

Fund Summary

Fund	Payment Amount
01 - GENERAL FUND	100,504.67
20 - LIGHTING & LANDSCAPING-DISTRICT 1	7,494.86
25 - CAPITAL IMPROVEMENTS PROJECTS	680.24
30 - SEWER	18,031.27
31 - REFUSE/RECYCLING	104,047.85
32 - WATER	72,983.71
34 - PUBLIC TRANSPORTATION	637.94
Grand Total:	304,380.54

Account Summary

Account Number	Account Name	Payment Amount
01-100-41300-0000-1	Franchise Fees	-6,068.92
01-105-51800-0000-1	Clothing Allowance	518.36
01-105-57100-2502-1	Special Activities - Schola...	600.00
01-110-50500-0000-1	Health Insurance Premi...	31.00
01-111-50500-0000-1	Health Insurance Premi...	19.60
01-111-52200-0000-1	Contract Services	74.00
01-112-50500-0000-1	Health Insurance Premi...	13.00
01-112-53200-0000-1	Dues & Subscriptions	65.00
01-115-50500-0000-1	Health Insurance Premi...	106.36
01-115-57200-0000-1	Supplies - Office	37.13
01-130-52200-0000-1	Contract Services	5,983.83
01-130-54800-0000-1	Maintenance Agreements	579.89
01-130-56050-0000-1	Accounting/Auditing Ser...	682.50
01-130-56100-0000-1	Legal Services	9,814.50
01-140-50500-0000-1	Health Insurance Premi...	119.20
01-140-56000-0000-1	Professional Services - O...	2,284.00
01-150-50500-0000-1	Health Insurance Premi...	738.50
01-150-52000-0000-1	Conferences/Meetings/T...	632.00
01-150-52200-0000-1	Contract Services	2,415.78
01-150-52940-0000-1	Vehicles (Capital)	2,324.56
01-150-54000-0000-1	Fuel	5,887.18
01-150-56000-0000-1	Professional Services - O...	5,419.29
01-150-56400-0000-1	Repairs & Maint - Build &...	1,285.00
01-150-56600-0000-1	Repairs & Maintenance - ...	1,529.46
01-150-57200-0000-1	Supplies - Office	211.76
01-155-50500-0000-1	Health Insurance Premi...	101.00
01-155-51100-0000-1	Animal Disposal	674.46
01-155-56000-0000-1	Professional Services - O...	594.40
01-160-50500-0000-1	Health Insurance Premi...	10.40
01-165-50500-0000-1	Health Insurance Premi...	59.40
01-165-52000-0000-1	Conferences/Meetings/T...	159.00
01-165-56000-0000-1	Professional Services-Ot...	764.65
01-165-56600-0000-1	Repairs & Maintenance - ...	110.00
01-165-57400-0000-1	Supplies - Operating	125.35
01-175-50500-0000-1	Health Insurance Premi...	13.00
01-180-50500-0000-1	Health Insurance Premi...	235.53
01-180-51800-0000-1	Clothing Allowance	615.66
01-180-52200-0000-1	Contract Services	363.54
01-180-56410-0000-1	Repairs & Maintenance ...	1,266.00
01-180-56500-0000-1	Repairs/Maintenance St...	42.65
01-180-56600-0000-1	Repairs/Maintenance - ...	715.42
01-180-56800-0000-1	Safety Equipment	142.89
01-180-57400-0000-1	Supplies - Operating	1,570.09
01-180-57800-0000-1	Telephone & Communic...	44.94
01-180-58000-0000-1	Utilities	1,528.56
01-180-58100-0000-1	Street Lighting	2,825.42

Account Summary

Account Number	Account Name	Payment Amount
01-185-56400-0000-1	Repairs & Maint - Build &..	809.91
01-185-58000-0000-1	Utilities	1,648.66
01-190-50500-0000-1	Health Insurance Premi...	49.00
01-190-56400-0000-1	Repairs & Maint - Build &..	2,025.01
01-190-56800-0000-1	Safety Equipment	1,121.93
01-190-57400-0000-1	Supplies - Operating	2,208.96
01-190-58000-0000-1	Utilities	3,544.10
01-20200-0000-1	Accounts Payable	960.00
01-20800-0000-1	Pension Payable	12,796.23
01-22050-0000-1	Federal Withholding Pay...	8,112.28
01-22100-0000-1	FICA Payable	11,520.36
01-22150-0000-1	Medicare Payable	2,694.38
01-22200-0000-1	State Withholding Payab...	4,495.86
01-22250-0000-1	SUTA Payable	114.02
01-22275-0000-1	ETT Payable	2.65
01-22700-0000-1	Disability LTD	129.49
01-22800-0000-1	Accident	19.34
01-22900-0000-1	Life	68.88
01-22950-0000-1	Cancer-American Fidelity	13.53
01-24000-0000-1	Deposits	350.00
01-24600-8207-1	Deferred Revenue - McF...	500.00
01-310-52200-0000-1	Contract Services	54.74
20-200-50500-0000-1	Health Insurance Premi...	148.30
20-200-51800-0000-1	Clothing Allowance	210.05
20-200-52200-0000-1	Contract Services	3,100.00
20-200-56700-0000-1	Repairs & Maintenance -...	33.55
20-200-57400-0000-1	Supplies - Operating	846.46
20-200-57800-0000-1	Telephone & Communic...	8.98
20-200-58100-0000-1	Street Lighting	3,147.52
25-000-52960-2401-1	Street & Roads (Capital) -..	680.24
30-500-50500-0000-1	Health Insurance Premi...	462.16
30-500-51800-0000-1	Clothing Allowance	476.08
30-500-53200-0000-1	Dues & Subscriptions	30.84
30-500-53800-0000-1	Equipment Rental	2,138.41
30-500-56050-0000-1	Accounting/Auditing Ser...	682.50
30-500-56400-0000-1	Repairs & Maint - Build &..	3,715.18
30-500-56410-0000-1	Repairs & Maintenance ...	6,966.00
30-500-56600-0000-1	Repairs & Maintenance -...	1,379.48
30-500-57200-0000-1	Supplies - Office	37.13
30-500-57400-0000-1	Supplies - Operating	1,509.02
30-500-57800-0000-1	Telephone & Communic...	193.14
30-500-58000-0000-1	Utilities	441.33
31-505-50500-0000-1	Health Insurance Premi...	168.64
31-505-52400-0000-1	Contract Services - Refus...	85,675.73
31-505-52500-0000-1	Contract Services - Recyc...	17,851.35
31-505-56050-0000-1	Accounting/Auditing Ser...	315.00
31-505-57200-0000-1	Supplies - Office	37.13
32-510-50500-0000-1	Health Insurance Premi...	374.68
32-510-51800-0000-1	Clothing Allowance	400.47
32-510-52200-0000-1	Contract Services	694.68
32-510-52910-2313-1	Buildings & Improvemen...	3,315.82
32-510-56000-0000-1	Professional Services - O...	359.70
32-510-56050-0000-1	Accounting/Auditing Ser...	708.75
32-510-56400-0000-1	Repairs & Maint - Build &..	642.62
32-510-56410-0000-1	Repairs & Maintenance- ...	359.39
32-510-56600-0000-1	Repairs & Maintenance -...	85.98
32-510-57200-0000-1	Supplies - Office	37.13
32-510-57400-0000-1	Supplies - Operating	156.84

Account Summary

Account Number	Account Name	Payment Amount
32-510-57800-0000-1	Telephone & Communic...	188.10
32-510-58000-0000-1	Utilities	65,659.55
34-520-50500-0000-1	Health Insurance Premi...	52.00
34-520-51800-0000-1	Clothing Allowance	35.02
34-520-56050-0000-1	Accounting/Auditing Ser...	236.25
34-520-56600-0000-1	Repairs & Maintenance -...	269.73
34-520-57800-0000-1	Telephone & Communic...	44.94
	Grand Total:	304,380.54

Project Account Summary

Project Account Key	Payment Amount
None	304,380.54
Grand Total:	304,380.54



Payroll Set: City-City of McFarland

Department: 105 - City Council

Employee Number	Pay Code	# of Payments	Units	Pay Amount
Avo100	Salary - Elected - Salary - Elected	1	0	200
	Total:		0	200
Cano100	Salary - Elected - Salary - Elected	1	0	200
	Total:		0	200
GON610	Salary - Elected - Salary - Elected	1	0	200
	Total:		0	200
GUT100	Salary - Elected - Salary - Elected	2	0	400
	Total:		0	400
PER100	Salary - Elected - Salary - Elected	1	0	200
	Total:		0	200
105 - City Council Total:			0	1200

Department: 110 - City Administration

Employee Number	Pay Code	# of Payments	Units	Pay Amount
AYN100	Bachelor's Degree - Bachelor's D	2	0	92.3
	Cash-in-Lieu - Cash-in-Lieu	2	0	369.24
	Holiday Pay - Holiday Pay	1	9	219.87
	Hourly - Hourly	2	108	2638.44
	OT - Overtime	2	3.09	113.23
	Sick - Sick Pay	1	14.42	352.28
	Total:		134.51	3785.36
CAN110	Hourly - Hourly	1	18.33	302.45
	Total:		18.33	302.45

[Nun100](#)

Bilingual - Bilingual	2	0	92.3
Comp Time Earned - Comp Time	1	7.5	0
Holiday Pay - Holiday Pay	1	9	274.59
Hourly - Hourly	2	140	4271.4
Hourly - Reg - Hourly - Regular	1	1.58	48.21
Live Scan - Live Scan	2	0	27.7
OT - Overtime	2	14.07	643.92
Sick - Sick Pay	1	11	335.61
Total:		183.15	5693.73

[VIR100](#)

Holiday Pay - Holiday Pay	1	8	732.89
Salary - Salary	2	152	13924.81
Salary Actual Time - Salary Actua	2	201.56	0
Total:		361.56	14657.7

110 - City Administration Total: 697.55 24439.24

Department: 111 - City Clerk

Employee Number	Pay Code	# of Payments	Units	Pay Amount
DEL200	Bachelor's Degree - Bachelor's D	2	0	92.3
	Holiday Pay - Holiday Pay	1	9	267.93
	Live Scan - Live Scan	1	0	13.85
	Notary - Notary	2	0	27.7
	Personal - Personal Day	1	9	267.93
	Salary - Salary	2	142	4227.32
	Salary Actual Time - Salary Actua	2	153.92	0
	Total:		313.92	4897.03

111 - City Clerk Total: 313.92 4897.03

Department: 112 - Human Resources

Employee Number	Pay Code	# of Payments	Units	Pay Amount
MCC100	Holiday Pay - Holiday Pay	1	8	376.35
	Salary - Salary	2	152	7150.57
	Salary Actual Time - Salary Actua	2	164.84	0
	Total:		324.84	7526.92

112 - Human Resources Total: 324.84 7526.92

Department: 115 - Finance & Accounting

Employee Number	Pay Code	# of Payments	Units	Pay Amount
ARC100	Bilingual - Bilingual	2	0	92.3
	Holiday Pay - Holiday Pay	1	8	380.72
	Personal - Personal Day	1	8	380.72
	Salary - Salary	2	132	6281.88
	Salary Actual Time - Salary Actual Time	2	157.57	0
	Vacation - Vacation Pay	1	12	571.08
	Total:			317.57
ARR100	Holiday Pay - Holiday Pay	1	9	180.45
	Hourly - Hourly	2	135.5	2716.77
	Hourly - Reg - Hourly - Regular	1	4.75	95.24
	OT - Overtime	2	5.78	173.83
	Sick - Sick Pay	1	5.92	118.7
	Vacation - Vacation Pay	1	9	180.45
	Total:			169.95
AYO110	Holiday Pay - Holiday Pay	1	9	189.63
	Hourly - Hourly	2	146.33	3083.17
	OT - Overtime	2	3.56	112.51
	Sick - Sick Pay	1	3.76	79.22
	Total:			162.65
ESP100	Bachelor's Degree - Bachelor's D	2	0	92.3
	Bilingual - Bilingual	2	0	92.3
	Holiday Pay - Holiday Pay	1	9	274.59
	Hourly - Hourly	2	139	4240.89
	Hourly - Reg - Hourly - Regular	2	1.44	43.94
	Sick - Sick Pay	1	3	91.53
	Vacation - Vacation Pay	1	9	274.59
	Total:			161.44
GON600	Bilingual - Bilingual	2	0	92.3
	Comp Time Earned - Comp Time	2	7.54	0
	Holiday Pay - Holiday Pay	1	9	274.59
	Hourly - Hourly	2	148.75	4538.36
	Vacation - Vacation Pay	1	2.25	68.65
	Total:			167.54
TOR100	Comp Time Earned - Comp Time	2	8.99	0
	Comp Time Taken - Comp Time	2	1.95	53.06
	Holiday - Holiday Pay	1	0	11.16
	Holiday Pay - Holiday Pay	1	9	219.87
	Hourly - Hourly	3	134.67	3590.51
	Sick - Sick Pay	2	14.38	369.13
	Total:			168.99

VAC110	Bilingual - Bilingual	2	0	92.3
	Holiday Pay - Holiday Pay	1	9	180.45
	Hourly - Hourly	2	133.25	2671.66
	Hourly - Reg - Hourly - Regular	1	1.61	32.28
	OT - Overtime	1	5.33	160.3
	Personal - Personal Day	1	9	180.45
	Sick - Sick Pay	1	8.75	175.44
	Total:		166.94	3492.88

VEL100	Bilingual - Bilingual	2	0	92.3
	Holiday - Holiday Pay	1	0	11.7
	Holiday Pay - Holiday Pay	1	9	231.03
	Hourly - Hourly	3	150.83	4206.01
	OT - Overtime	3	9.65	395.93
	Total:		169.48	4936.97

115 - Finance & Accounting Total: 1484.56 37394.29

Department: 140 - Planning

Employee Number	Pay Code	# of Payments	Units	Pay Amount
AYO120	Hourly - Hourly	1	17	280.5
	Total:		17	280.5

DEL100	Bachelor's Degree - Bachelor's D	2	0	92.3
	Holiday Pay - Holiday Pay	1	9	407.68
	Notary - Notary	2	0	27.7
	Salary - Salary	2	142	6432.34
	Salary Actual Time - Salary Actua	2	163.66	0
	Vacation - Vacation Pay	1	9	407.68
	Total:		323.66	7367.7

HER110	Hourly - Hourly	1	21.59	356.24
	Total:		21.59	356.24

SALD100	Admin Time*Salary EE - Adminis	2	16	526.92
	Holiday Pay - Holiday Pay	1	8	263.46
	Salary - Salary	2	96	3161.55
	Salary Actual Time - Salary Actua	2	116.35	0
	Vacation - Vacation Pay	1	40	1317.31
	Total:		276.35	5269.24

[SNY100](#)

Cash-in-Lieu - Cash-in-Lieu	2	0	369.24
Holiday Pay - Holiday Pay	1	8	403.84
Salary - Salary	2	152	7672.96
Salary Actual Time - Salary Actua	1	96.75	0
Total:		256.75	8446.04

140 - Planning Total: 895.35 21719.72

Department: 150 - Police

Employee Number

[BAR100](#)

Pay Code	# of Payments	Units	Pay Amount
Bachelor's Degree - Bachelor's D	2	0	92.3
Comp Time Earned PD - Comp T	2	60	0
Shift Differentials - Shift Differen	2	107	60.64
SRO - School Resource Officer	2	160	4534.4
SRO Holiday - School Resource (1	8	226.72
SRO-OT - School Resource Office	1	8	340.08
Total:		343	5254.14

[BOT100](#)

Holiday Pay - Holiday Pay	1	12	357.24
Hourly - Hourly	2	156	4644.12
OT - Overtime	2	38.5	1719.23
PD - Court Appear - PD - Court A	1	6	267.94
Shift Differentials - Shift Differen	2	181	107.77
Total:		393.5	7096.3

[CAZ100151](#)

Bilingual - Bilingual	2	0	92.3
Holiday Pay - Holiday Pay	1	12	394.32
Hourly - Hourly	2	85	2793.1
OT - Overtime	1	12	591.48
Shift Differentials - Shift Differen	2	59	38.77
Sick - Sick Pay	1	12	394.32
Workers Comp - Workers Comp	2	48	1577.28
Total:		228	5881.57

[ALB100142](#)

Cash-in-Lieu - Cash-in-Lieu	2	0	369.24
Holiday Pay - Holiday Pay	1	12	414.24
Hourly - Hourly	2	110.5	3814.46
OT - Overtime	2	86	4453.08
Shift Differentials - Shift Differen	2	118.5	81.81
Sick - Sick Pay	1	5.5	189.86
Vacation - Vacation Pay	1	40	1380.8
Total:		372.5	10703.49

DEW100147	Holiday Pay - Holiday Pay	1	12	530.28
	Hourly - Hourly	2	144	6363.37
	Hourly - Reg - Hourly - Regular	1	12	530.28
	OT - Overtime	2	62	4109.68
	Personal - Personal Day	1	12	530.28
	Shift Differentials - Shift Differen	2	201.5	178.11
	Total:		443.5	12242
EST150	Bilingual - Bilingual	2	0	92.3
	Holiday Pay - Holiday Pay	1	12	394.32
	Hourly - Hourly	2	156	5126.16
	Hourly - Reg - Hourly - Regular	1	12	394.32
	OT - Overtime	2	11.5	566.84
	Shift Differentials - Shift Differen	2	42.5	27.94
	Total:		234	6601.88
GAL100149	Advanced POST - Advanced POS	2	0	138.46
	Holiday Pay - Holiday Pay	1	12	457.32
	Hourly - Hourly	2	156	5945.17
	Hourly - Reg - Hourly - Regular	1	12	457.32
	OT - Overtime	2	76	4344.54
	Shift Differentials - Shift Differen	2	78.25	59.66
	Total:		334.25	11402.47
GAR100114	Bilingual - Bilingual	2	0	92.3
	Hourly - Hourly	2	95	2209.7
	Shift Differentials - Shift Differen	2	94	43.73
Total:		189	2345.73	
GAR100150	Advanced POST - Advanced POS	2	0	138.46
	Comp Time Earned PD - Comp 1	2	52.5	0
	Holiday Pay - Holiday Pay	1	8	353.52
	Hourly - Hourly	2	160	7070.41
	OT - Overtime	2	23	1524.57
	Shift Differentials - Shift Differen	2	46.5	41.11
	Total:		290	9128.07
HAN100112	Cash-in-Lieu - Cash-in-Lieu	2	0	369.24
	Holiday Pay - Holiday Pay	1	12	435.24
	Hourly - Hourly	2	156	5658.12
	Hourly - Reg - Hourly - Regular	1	7	253.89
	Intermediate POST - Intermedia	2	0	92.3
	Shift Differentials - Shift Differen	2	127	92.12
	Total:		302	6900.91

KNO100	Holiday Pay - Holiday Pay	1	8	473.08
	Personal - Personal Day	1	8	473.08
	Salary - Salary	2	144	8515.38
	Total:		160	9461.54
LOP125	Bachelor's Degree - Bachelor's D	2	0	92.3
	Bilingual - Bilingual	2	0	92.3
	Holiday Pay - Holiday Pay	1	12	340.08
	Hourly - Hourly	2	142	4024.28
	OT - Overtime	2	25	1062.75
	Shift Differentials - Shift Differen	1	4	2.27
	Standby ET - Standby ET	2	28	400.12
	Total:		211	6014.1
MAD100	Bilingual - Bilingual	2	0	92.3
	Comp Time Earned PD - Comp T	1	18	0
	Comp Time Taken PD - Comp Tir	1	12	240.6
	Holiday Pay - Holiday Pay	1	12	240.6
	Hourly - Hourly	2	132	2646.6
	Hourly - Reg - Hourly - Regular	1	12	240.6
	OT - Overtime	2	26.58	799.4
	Shift Differentials - Shift Differen	2	158.83	63.69
	Total:		371.41	4323.79
MUL100	Advanced POST - Advanced POS	2	0	138.46
	Bachelor's Degree - Bachelor's D	2	0	92.3
	Holiday Pay - Holiday Pay	1	12	457.32
	Hourly - Hourly	2	144	5487.84
	OT - Overtime	2	71	4058.72
	Shift Differentials - Shift Differen	2	201	153.2
	Vacation - Vacation Pay	1	12	457.32
	Total:		440	10845.16
NAV100	Holiday Pay - Holiday Pay	1	10	244.3
	Hourly - Hourly	2	150	3664.5
	Hourly - Reg - Hourly - Regular	1	10	244.3
	OT - Overtime	1	5	183.23
	Shift Differentials - Shift Differen	1	3	1.47
	Total:		178	4337.8
NIN100	Comp Time Taken PD - Comp Tir	2	24	714.48
	Holiday Pay - Holiday Pay	1	12	357.24
	Hourly - Hourly	2	84	2500.68
	Hourly - Reg - Hourly - Regular	1	12	357.24
	Shift Differentials - Shift Differen	2	96	57.16
	Sick - Sick Pay	1	24	714.48
	Vacation - Vacation Pay	1	24	714.48
	Total:		276	5415.76

OLL100	Bachelor's Degree - Bachelor's D	2	0	92.3
	Cash-in-Lieu - Cash-in-Lieu	2	0	369.24
	Comp Time Earned PD - Comp T	2	15.01	0
	Comp Time Taken PD - Comp Tir	2	50	1002.5
	Holiday Pay - Holiday Pay	1	10	200.5
	Hourly - Hourly	2	100	2005
	Hourly - Reg - Hourly - Regular	1	10	200.5
	OT - Overtime	1	24.42	734.44
	Shift Differentials - Shift Differen	2	17.25	6.91
	Total:		226.68	4611.39
OLM100	Holiday Pay - Holiday Pay	1	10	531.25
	Salary - Salary	2	150	7968.75
	Salary Actual Time - Salary Actua	2	150	0
Total:		310	8500	
PES100152	Advanced POST - Advanced POS	2	0	138.46
	Cash-in-Lieu - Cash-in-Lieu	2	0	369.24
	Hourly - Reg - Hourly - Regular	1	7	253.89
	Shift Differentials - Shift Differen	2	6.5	4.71
	SRO - School Resource Officer	2	156	5658.12
	SRO Holiday - School Resource O	1	8	290.16
Total:		177.5	6714.58	
SHA100152	Bachelor's Degree - Bachelor's D	2	0	92.3
	Cash-in-Lieu - Cash-in-Lieu	2	0	369.24
	Holiday Pay - Holiday Pay	1	12	530.28
	Hourly - Hourly	2	156	6893.65
	OT - Overtime	2	63.65	4219.04
	PD - Court Appear - PD - Court A	1	3	198.86
	Shift Differentials - Shift Differen	2	120.65	106.64
	Supervisory Post - Supervisory P	2	0	184.6
	Total:		355.3	12594.61
TAF200	Cash-in-Lieu - Cash-in-Lieu	2	0	369.24
	Comp Time Earned PD - Comp T	2	42	0
	Comp Time Taken PD - Comp Tir	1	1	33.68
	Holiday Pay - Holiday Pay	1	12	404.16
	Hourly - Hourly	2	143.5	4833.08
	Hourly - Reg - Hourly - Regular	1	8	269.44
	OT - Overtime	1	12.5	631.5
	Shift Differentials - Shift Differen	2	24	16.16
	Sick - Sick Pay	1	3.5	117.88
	Total:		246.5	6675.14

VEL200	Bilingual - Bilingual	2	0	92.3
	Holiday Pay - Holiday Pay	1	12	293.16
	Hourly - Hourly	2	144	3517.92
	OT - Overtime	2	44	1612.38
	Shift Differentials - Shift Differen	2	168	82.08
	Total:		368	5597.84
WEIS100	Advanced POST - Advanced POS	2	0	138.46
	Holiday Pay - Holiday Pay	1	12	435.24
	Hourly - Hourly	2	144	5355.36
	Hourly - Reg - Hourly - Regular	1	12	435.24
	K9 OT - K9 Overtime	2	14	781
	OT - Overtime	2	28	1578.54
	Shift Differentials - Shift Differen	2	86	63.19
	Vacation - Vacation Pay	1	12	457.32
	Total:		308	9244.35
WIL100150	Hourly - Hourly	2	80.09	12013.5
	Total:		80.09	12013.5
	150 - Police Total:		6838.23	183906.12

Department: 155 - Animal Control

Employee Number	Pay Code	# of Payments	Units	Pay Amount
LOP100	Holiday Pay - Holiday Pay	1	12	240.6
	Hourly - Hourly	2	148	2967.41
	OT - Overtime	2	96.1	2890.21
	Total:		256.1	6098.22
McG100	Cash Out - VAC - Cash Out - Vacc	1	55.44	1734.16
	Holiday Pay - Holiday Pay	1	9	281.52
	Hourly - Hourly	1	31	969.68
	OT - Overtime	1	2.75	129.03
	Total:		98.19	3114.39
MUN100	Admin Leave - Admin Leave	1	74.08	1485.3
	Holiday Pay - Holiday Pay	1	9	180.45
	Hourly - Hourly	2	67.92	1361.8
	Hourly - Reg - Hourly - Regular	1	9	180.45
	OT - Overtime	1	8.34	250.83
	Sick - Sick Pay	1	9	180.45
	Standby ET - Standby ET	1	7	100.03
	Total:		184.34	3739.31

[PER300](#)

Comp Time Earned - Comp Time	1	32.27	0
Holiday Pay - Holiday Pay	1	9	180.45
Hourly - Hourly	2	151	3027.55
OT - Overtime	1	47.01	1413.83
Total:		239.28	4621.83

155 - Animal Control Total: 777.91 17573.75

Department: 160 - Building Inspection

Employee Number

[PER200](#)

Pay Code	# of Payments	Units	Pay Amount
Cash-in-Lieu - Cash-in-Lieu	1	0	184.62
Holiday Pay - Holiday Pay	1	9	209.34
Hourly - Hourly	1	40.83	949.71
Hourly - Reg - Hourly - Regular	1	1.25	29.08
Vacation - Vacation Pay	1	30.17	701.75
Total:		81.25	2074.5

160 - Building Inspection Total: 81.25 2074.5

Department: 175 - Grants Administration

Employee Number

[ROSA100](#)

Pay Code	# of Payments	Units	Pay Amount
Bachelor's Degree - Bachelor's D	2	0	92.3
Holiday Pay - Holiday Pay	1	9	351.55
Salary - Salary	2	151	5898.15
Salary Actual Time - Salary Actua	2	151.32	0
Total:		311.32	6342

175 - Grants Administration Total: 311.32 6342

Department: 180 - Public Works

Employee Number

[CABR100](#)

Pay Code	# of Payments	Units	Pay Amount
Holiday Pay - Holiday Pay	1	8	319.22
Salary - Salary	2	140	5586.42
Salary Actual Time - Salary Actua	2	147.24	0
Vacation - Vacation Pay	1	12	478.84
Total:		307.24	6384.48

[CAS200](#)

Bachelor's Degree - Bachelor's D	2	0	92.3
Holiday Pay - Holiday Pay	1	9	351.55
Salary - Salary	2	151	5898.15
Salary Actual Time - Salary Actua	2	152.66	0
Total:		312.66	6342

CORT100	Hourly - Hourly	1	62.09	1480.23
	OT - Overtime	1	11.91	425.9
	Total:		74	1906.13
DRA100	Bachelor's Degree - Bachelor's D	1	0	46.15
	Cash Out - Comp - Cash Out - Co	1	7.83	156.99
	Cash Out - VAC - Cash Out - Vac	1	27.21	545.56
	Holiday Pay - Holiday Pay	1	9	180.45
	Hourly - Hourly	1	27.08	542.95
	Sick - Sick Pay	1	4	80.2
	Total:		75.12	1552.3
GUE100	Comp Time Earned - Comp Time	1	5.16	0
	Holiday Pay - Holiday Pay	1	9	288.54
	Hourly - Hourly	2	115	3686.9
	Hourly - Reg - Hourly - Regular	1	0.32	10.26
	OT - Overtime	1	3.44	165.43
	Personal - Personal Day	1	9	288.54
	Sick - Sick Pay	1	9	288.54
	Vacation - Vacation Pay	1	18	577.08
	Total:		168.92	5305.29
HER400	Holiday Pay - Holiday Pay	1	8	530
	Salary - Salary	2	152	10070
	Salary Actual Time - Salary Actua	2	174.75	0
Total:		334.75	10600	
NEV100	Comp Time Earned - Comp Time	1	0.12	0
	Comp Time Taken - Comp Time	1	10.5	226.8
	Holiday Pay - Holiday Pay	1	9	194.4
	Hourly - Hourly	2	128.5	2775.6
	Hourly - Reg - Hourly - Regular	1	0.01	0.22
	OT - Overtime	1	0.16	5.18
	Sick - Sick Pay	1	12	259.2
	Total:		160.29	3461.4
TEL100	Holiday Pay - Holiday Pay	1	9	214.56
	Hourly - Hourly	2	121	2884.64
	Hourly - Reg - Hourly - Regular	1	0.73	17.4
	OT - Overtime	2	16.64	595.04
	Personal - Personal Day	1	9	214.56
	Sick - Sick Pay	1	21	500.64
Total:		177.37	4426.84	
180 - Public Works Total:			1610.35	39978.44

Department: 190 - Facilities Maintenance

Employee Number	Pay Code	# of Payments	Units	Pay Amount
DOM100	Comp Time Taken - Comp Time	1	9	255.06
	Holiday Pay - Holiday Pay	1	9	255.06
	Hourly - Hourly	2	142	4024.28
	Hourly - Reg - Hourly - Regular	1	1.32	37.41
	OT - Overtime	2	18.54	788.14
	Total:		179.86	5359.95
190 - Facilities Maintenance Total:			179.86	5359.95

Department: 200 - Lighting & Landscaping

Employee Number	Pay Code	# of Payments	Units	Pay Amount
Cruz100	Holiday Pay - Holiday Pay	1	9	225.36
	Hourly - Hourly	2	142	3555.68
	Hourly - Reg - Hourly - Regular	1	0.42	10.52
	OT - Overtime	2	5.08	190.81
	Sick - Sick Pay	1	9	225.36
	Total:		165.5	4207.73
200 - Lighting & Landscaping Total:			165.5	4207.73

Department: 500 - Sewer

Employee Number	Pay Code	# of Payments	Units	Pay Amount
CIS400	Holiday Pay - Holiday Pay	1	9	303.12
	Hourly - Hourly	2	131.58	4431.61
	Hourly - Reg - Hourly - Regular	2	2.58	86.89
	OT - Overtime	2	20.92	1056.88
	PW Cert - Grade 1 - Public Work	2	0	23.08
	Sick - Sick Pay	1	9	303.12
	Standby ET - Standby ET	2	12	171.48
	Vacation - Vacation Pay	2	10.42	350.95
	Total:		195.5	6727.13
HER300	Comp Time Earned - Comp Time	1	37.01	0
	Holiday - Holiday Pay	1	0	20.61
	Holiday Pay - Holiday Pay	1	9	199.26
	Hourly - Hourly	3	151	3688.93
	OT - Overtime	3	23.39	857.12
	Standby ET - Standby ET	2	16	228.64
	Total:		236.4	4994.56
500 - Sewer Total:			431.9	11721.69

Department: 510 - Water

Employee Number	Pay Code	# of Payments	Units	Pay Amount
CAR100	Comp Time Taken - Comp Time	1	2	64.12
	Holiday Pay - Holiday Pay	1	9	288.54
	Hourly - Hourly	2	144	4616.64
	Hourly - Reg - Hourly - Regular	2	6.49	208.07
	OT - Overtime	2	42.78	2057.29
	Sick - Sick Pay	2	5	160.3
	Standby ET - Standby ET	2	11	157.19
	Total:			220.27
CEJ110	Holiday Pay - Holiday Pay	1	9	261.36
	Hourly - Hourly	2	151	4385.04
	OT - Overtime	2	50.23	2188.01
	Standby ET - Standby ET	1	7	100.03
Total:			217.23	6934.44
RAM200	Holiday Pay - Holiday Pay	1	9	219.87
	Hourly - Hourly	2	150.57	3678.43
	OT - Overtime	2	34.73	1125.25
	Standby ET - Standby ET	2	10	142.9
Total:			204.3	5166.45
VIL100	Cash-in-Lieu - Cash-in-Lieu	2	0	369.24
	Comp Time Taken - Comp Time	1	9	236.79
	Holiday Pay - Holiday Pay	1	9	236.79
	Hourly - Hourly	2	49.24	1295.51
	Personal - Personal Day	1	9	236.79
	PW Cert - Grade 2 - Public Work	2	0	46.16
	Total:			76.24
510 - Water Total:			718.04	22074.32

Department: 520 - Public Transit

Employee Number	Pay Code	# of Payments	Units	Pay Amount
MUN200	Holiday Pay - Holiday Pay	1	9	209.34
	Hourly - Hourly	2	133.08	3095.44
	Hourly - Reg - Hourly - Regular	1	1.08	25.12
	OT - Overtime	2	6.4	223.29
	Personal - Personal Day	1	9	209.34
	Sick - Sick Pay	1	6	139.56
	Total:			164.56
520 - Public Transit Total:			164.56	3902.09
Report Total:			14995.14	394317.79



Payroll Set: City-City of McFarland

Account	Account Description	Units	Pay Amount
	BENEFIT AND NON GL TRANSACTIONS	2116.72	0
	- Total:	2116.72	0
01-105-50100-0000-1	Salaries - Permanent Employees	0	936
01-110-50100-0000-1	Salaries - Permanent Employees	232.21	7507.74
01-110-50150-0000-1	Wages - Temporary Employees	31.06	512.58
01-110-50200-0000-1	Overtime	10.13	435.2
01-110-50350-0000-1	Stipends	0	521.56
01-111-50100-0000-1	Salaries - Permanent Employees	64	1905.26
01-111-50350-0000-1	Stipends	0	113.52
01-112-50100-0000-1	Salaries - Permanent Employees	40	1881.74
01-115-50100-0000-1	Salaries - Permanent Employees	164.43	6405.09
01-115-50200-0000-1	Overtime	0.96	39.59
01-115-50350-0000-1	Stipends	0	101.58
01-140-50100-0000-1	Salaries - Permanent Employees	416.01	16985.76
01-140-50150-0000-1	Wages - Temporary Employees	13.12	216.49
01-140-50350-0000-1	Stipends	0	396.93
01-150-50100-0000-1	Salaries - Permanent Employees	5913.36	148062.87
01-150-50200-0000-1	Overtime	647.18	34099.25
01-150-50350-0000-1	Stipends	28	4530.83
01-155-50100-0000-1	Salaries - Permanent Employees	387.96	8850.04
01-155-50200-0000-1	Overtime	92.62	2830.63
01-155-50350-0000-1	Stipends	3.5	50.02
01-160-50100-0000-1	Salaries - Permanent Employees	144.75	5278.13
01-160-50150-0000-1	Wages - Temporary Employees	12.74	210.12
01-160-50350-0000-1	Stipends	0	240.01
01-165-50100-0000-1	Salaries - Permanent Employees	245.48	5700.95
01-165-50200-0000-1	Overtime	61.58	1853.27
01-165-50350-0000-1	Stipends	3.5	50.01
01-175-50100-0000-1	Salaries - Permanent Employees	279	11200.89
01-175-50350-0000-1	Stipends	0	133.84
01-180-50100-0000-1	Salaries - Permanent Employees	616.05	17799.92
01-180-50200-0000-1	Overtime	29.48	1102.14
01-180-50350-0000-1	Stipends	0	4.62
01-190-50100-0000-1	Salaries - Permanent Employees	161.32	4571.81
01-190-50200-0000-1	Overtime	18.54	788.14
	01 - GENERAL FUND Total:	9616.98	285316.53
20-200-50100-0000-1	Salaries/Permanent Employees	159.03	3672.64
20-200-50200-0000-1	Overtime	7.75	280.22

Account	Account Description	Units	Pay Amount
	20 - LIGHTING & LANDSCAPING-DISTRICT 1 Total:	166.78	3952.86
<u>30-500-50100-0000-1</u>	Salaries - Permanent Employees	989.52	34075.62
<u>30-500-50200-0000-1</u>	Overtime	52.04	2180.18
<u>30-500-50350-0000-1</u>	Stipends	28	646.19
	30 - SEWER Total:	1069.56	36901.99
<u>31-505-50100-0000-1</u>	Salaries - Permanent Employees	455.16	16497.06
<u>31-505-50200-0000-1</u>	Overtime	7.73	266.18
<u>31-505-50350-0000-1</u>	Stipends	0	122.81
	31 - REFUSE/RECYCLING Total:	462.89	16886.05
<u>32-510-50100-0000-1</u>	Salaries - Permanent Employees	1234.01	40677.94
<u>32-510-50200-0000-1</u>	Overtime	135.64	5641.17
<u>32-510-50350-0000-1</u>	Stipends	28	1039.16
	32 - WATER Total:	1397.65	47358.27
<u>34-520-50100-0000-1</u>	Salaries - Permanent Employees	158.16	3678.8
<u>34-520-50200-0000-1</u>	Overtime	6.4	223.29
	34 - PUBLIC TRANSPORTATION Total:	164.56	3902.09
	Report Total:	14995.14	394317.79



Payroll Set: City-City of McFarland

Pay Code	Description	# of Payments	Units	Pay Amount
Admin Leave - Admin Lea	Admin Leave	1	74.08	1485.3
Admin Time*Salary EE - A	Administrative Time Salary EE	2	16	526.92
Advanced POST - Advanc	Advanced POST Certificate	10	0	692.3
Bachelor's Degree - Bache	Bachelor's Degree	23	0	1061.45
Bilingual - Bilingual	Bilingual	24	0	1107.6
Cash Out - Comp - Cash O	Cash Out - Comp Time	1	7.83	156.99
Cash Out - VAC - Cash Ou	Cash Out - Vacation	2	82.65	2279.72
Cash-in-Lieu - Cash-in-Lie	Cash-in-Lieu	19	0	3507.78
Comp Time Earned - Com	Comp Time Earned	9	98.59	0
Comp Time Earned PD - (Comp Time Earned PD	9	187.51	0
Comp Time Taken - Comp	Comp Time Taken	6	32.45	835.83
Comp Time Taken PD - Cc	Comp Time Taken PD	6	87	1991.26
Holiday - Holiday Pay	Holiday Pay	3	0	43.47
Holiday Pay - Holiday Pay	Holiday Pay	58	564	18442.96
Hourly - Hourly	Hourly	98	6018.23	182881.45
Hourly - Reg - Hourly - Re	Hourly - Regular	28	146.58	4462.11
Intermediate POST - Inter	Intermediate POST Certificate	2	0	92.3
K9 OT - K9 Overtime	K9 Overtime	2	14	781
Live Scan - Live Scan	Live Scan	3	0	41.55
Notary - Notary	Notary	4	0	55.4
OT - Overtime	Overtime	67	1039.05	48151.38
PD - Court Appear - PD - C	PD - Court Appearance	2	9	466.8
Personal - Personal Day	Personal Day	9	82	2781.69
PW Cert - Grade 1 - Public	Public Works Certification - Grade 1	2	0	23.08
PW Cert - Grade 2 - Public	Public Works Certification - Grade 2	2	0	46.16
Salary - Salary	Salary	26	1856	92788.28
Salary - Elected - Salary - I	Salary - Elected Officials	6	0	1200
Salary Actual Time - Salar	Salary Actual Time Worked	23	1830.62	0
Shift Differentials - Shift D	Shift Differentials	40	1940.48	1289.14
Sick - Sick Pay	Sick Pay	22	190.23	5075.82
SRO - School Resource O	School Resource Officer	4	316	10192.52
SRO Holiday - School Res	School Resource Officer Holiday Pay	2	16	516.88
SRO-OT - School Resource	School Resource Officer Overtime	1	8	340.08
Standby ET - Standby ET	Standby ET	12	91	1300.39
Supervisory Post - Superv	Supervisory POST Certificate	2	0	184.6
Vacation - Vacation Pay	Vacation Pay	15	239.84	7938.3
Workers Comp - Workers	Workers Comp Pay	2	48	1577.28
Report Total:			14995.14	394317.79

REGULAR CITY COUNCIL MINUTES

IN-PERSON MEETING

June 25, 2025

**MCFARLAND CITY COUNCIL
MCFARLAND SUCCESSOR AGENCY
MCFARLAND PUBLIC FINANCE AUTHORITY
MCFARLAND IMPROVEMENT AUTHORITY
MCFARLAND PARKING AUTHORITY**

CALL TO ORDER

Mayor Ayon called the meeting to order at 6:00p.m.

ROLL CALL

Councilmembers Present: Mayor Ayon, Vice-Mayor Cano, Councilmember Gutierrez, Councilmember Pérez, Councilmember Gonzalez

Councilmembers Absent: None

OFFICIALS PRESENT

City Manager Viramontes, City Attorney Hodges, Chief of Police Knox, Captain Olmos, Public Works Director Hernandez, Community Development Director Snyder, Human Resources Director McCuan, City Clerk De La Cruz

INVOCATION

Offered by Vice-Mayor Cano

PLEDGE OF ALLEGIANCE

Offered by Councilmember Gutierrez

APPROVE AGENDA AS TO FORM

*Motion by Vice Mayor Cano, seconded by Councilmember Pérez, to amend the agenda for the June 25, 2025, meeting to include a Promotional Ceremony for Officer Juan Estrada under Presentations, Introductions, and Awards, and to add a Closed Session item. Motion **Approved** by 5/0 Roll-Call Majority Vote.*

Roll Call Vote:

AYES: S. Ayon, R. Cano, M. Gutierrez, M. Pérez, A. Gonzalez

NOES: None

ABSENT: None

ABSTAIN: None

PASSED: 5-0

PRESENTATIONS, INTRODUCTIONS AND AWARDS

1. Promotional Ceremony – Juan Estrada

DEPARTMENTAL REPORTS

None

CONSENT AGENDA

1. Approval of Expense Report in the Amount of \$352,973.00 from 5/31/2025 to 6/13/2025.
2. Approval of June 11, 2025, Regular Meeting Minutes
3. Approval of June 16, 2025, Special Meeting Minutes
4. Approval of Resolution No. 2025-79 A RESOLUTION OF THE CITY COUNCIL OF THE CITY OF MCFARLAND ACCEPTING THE INTEREST IN REAL PROPERTY AND AUTHORIZING THE CUTY MANAGER TO SIGN CERTIFICATE OF ACCEPTACNE
5. Approval of Resolution No. 2025-81 A RESOLUTION OF THE CITY COUNCIL OF MCFARLAND APPROVING AN AGGREMENT WITH PLACER LABS, INC. FOR DATA ANALYTICS SERVICES
6. Approval of Resolution No. 2025-83 A RESOLUTION OF THE CITY COUNCIL OF THE CITY OF MCFARLAND APPROVING AN AGREEMENT WITH LASERFICHE FOR AN ONLINE RECORDS MANAGEMENT SYSTEM.
7. Approval of Resolution No. 2025-87 A RESOLUTION OF THE CITY COUNCIL OF MCFARLAND AUTHORIZING THE APPLICATION AND AMENDING THE PLHA PLAN FOR THE PERMANENT LOCAL HOUSING ALLOCATION PROGRAM
8. Approval of Resolution No. 2025-63 A RESOLUTION OF THE CITY COUNCIL OF MCFARLAND APPROVING CONDITIONAL USE PERMIT 2025-001, HOME OCCUPATION 2025-001, AND TWO VARIANCES TO ALLOW FOR A BABER STATION AT 310 4TH STREET
9. Approval of Resolution No. 2025-85 A RESOLUTION OF THE CITY COUNCIL OF THE CITY OF MCFARLAND APPROVING ADDENDUM NO. 01 TO THE EMPLOYMENT AGREEMENT WITH PAUL SALDANA FOR AN ADDITIONAL TWELVE MONTHS
10. Approval of Resolution 2025-86 A RESOLUTION OF THE CITY COUNCIL OF THE CITY OF MCFARLAND APPROVING THE SUBMISSION OF FIVE SEPARATE DEPARTMENT OF JUSTICE COMMUNITY ORIENTED POLICING SERVICE GRANT APPLICATIONS TO THE DEPARTMENT OF JUSTICE; AUTHORIZING THE CITY MANAGER TO TAKE ALL NECESSARY STEPS TO IMPLEMENT THE PROVISIONS OF THIS RESOLUTION; INCORPORATING RECITALS; PROVIDING FOR SEVERABILITY; AND ADOPTING AN EFFECTIVE DATE

*Motion by Councilmember Gonzalez, Second by Councilmember Gutierrez to Approve the Consent Agenda at the meeting of June 25, 2025. Motion **Approved** by 5/0 Roll-Call Majority Vote.*

Roll Call Vote:

AYES: S. Ayon, R. Cano, M. Gutierrez, M. Pérez, A. Gonzalez

NOES: None

ABSENT: None

ABSTAIN: None

PASSED: 5-0

PUBLIC HEARINGS

1. None

ADMINISTRATIVE AGENDA

11. Approval of Resolution No. 2025-80 A RESOLUTION OF THE CITY COUNCIL OF THE CITY OF MCFARLAND APPROVING THE CREATION AND JOB DESCRIPTION OF UTILITIES MANAGER

*Motion by Vice Mayor Cano, Second by Councilmember Pérez to Approve Resolution No. 2025-80 at the meeting of June 25, 2025. Motion **Approved** by 5/0 Roll-Call Majority Vote.*

Roll Call Vote:

AYES: S. Ayon, R. Cano, M. Gutierrez, M. Pérez, A. Gonzalez
NOES: None
ABSENT: None
ABSTAIN: None
PASSED: 5-0

12. Approval of Resolution No. 2025-88 A RESOLUTION OF THE CITY COUNCIL OF THE CITY OF MCFARLAND APPROVING A COMMUNITY GRANT TO THE COUGAR BOOSTER CLUB TO SUPPORT YOUTH PARTICIPATION IN SUMMER ATHLETIC EVENTS

*Motion by Vice Mayor Cano, Second by Councilmember Pérez to Approve Resolution No. 2025-88 at the meeting of June 25, 2025. Motion **Approved** by 5/0 Roll-Call Majority Vote.*

Roll Call Vote:

AYES: S. Ayon, R. Cano, M. Gutierrez, M. Pérez, A. Gonzalez
NOES: None
ABSENT: None
ABSTAIN: None
PASSED: 5-0

PUBLIC COMMENT

- 1. Kenny Williams

COUNCIL COMMENTS

None

REPORTS FROM CITY COUNCIL ON COMMITTEE/SPECIAL DISTRICT MEETINGS

- a. Kern Council of Governments (KCOG)- Mayor Ayon has been advocating for infrastructure projects. Additionally, Mayor Ayon has been advocating for funding for the City of McFarland.
- b. Kern Economic Development Corporation (KEDC)- Economic Development Manager Saldana provided an update that the KEDC budget passed.
- c. Kern Local Agency Formation Commission (LAFCO)- Resolution to restructure the Parks and Recreation operations and realign the subsidiary district under the City’s oversight, approved by Mayor Ayon. Mayor Ayon stated that a feasibility study will help make further decisions.
- d. Delano Mosquito Abatement District (DMAD)- Vice Mayor Cano provided an update that during their meeting on June 19, 2025, noted that there is an increase in mosquitos. West Nile is a concern with this increase. Furthermore, DMAD provides services to control mosquito population.
- e. San Joaquin Valley Air Pollution Control District (SJV)- No Report

COUNCIL STATEMENTS AND REPORTS

- A. Community Development Director Snyder gave an announcement that the Freedom Fest will take place on July 3, 2025, at McFarland High School in celebration of Independence Day. The event will feature hot dogs, various vendors, and family-friendly festivities for the community to enjoy.

CLOSED SESSION

- 1. Council approved settlement agreement with former Police Department Employee in the amount of \$4,000.00
- 2. Council provided directions to City Attorney to draft demand letter
- 3. No reportable action taken

ADJOURNEMENT

The City Council Meeting of June 25, 2025, adjourned at 7:50p.m.

CITY OF MCFARLAND

Erika De La Cruz, City Clerk



City of McFarland

City Council Meeting

STAFF REPORT

Agenda Item No. 4.
Section: CONSENT AGENDA
Meeting Date: July 9, 2025

TO: Honorable Mayor and Council Members

FROM: Diego Viramontes, City Manager
Yerlys Hernandez , Public Works Director

SUBJECT: Approval of Resolution No. 2025-97 A RESOLUTION OF THE CITY COUNCIL OF THE CITY OF MCFARLAND AUTHORIZING THE DESIGNATION OF THE CITY MANAGER AS THE AUTHORIZED REPRESENTATIVE TO SIGN AND FILE A FINANCIAL ASSISTANCE APPLICATION FOR A FINANCING AGREEMENT FROM THE STATE WATER RESOURCE CONTROL BOARD

SUMMARY:

The City of McFarland is continuing to pursue funding from the State Water Resources Control board for the planning, design and construction of the Waste Water Treatment Plant Expansion Project.

One of the requirements of the funding application is to designate an Authorized representative to sign and file for and on behalf of the city a financial assistance application for a financing agreement from the state water resources control board for the planning, design and construction of the project.

Staff proposes designating the City Manager as its Authorized Representative.

This Authorized Representative, is designated to provide the assurances, certifications, and commitments required for the financial assistance application, including executing a financial assistance agreement from the State Water Resources Control Board and any amendments or changes thereto

The Authorized Representative, is designated to represent the City in carrying out the City's responsibilities under the financing agreement, including certifying disbursement requests on behalf of the Entity and compliance with applicable state and federal laws.

FINANCIAL IMPACT:

There is no Financial Impact

RECOMMENDATION:

Staff Recommends approval of Resolution No. 2025-97 A RESOLUTION OF THE CITY COUNCIL OF THE CITY OF MCFARLAND AUTHORIZING THE DESIGNATION OF THE CITY MANAGER AS THE AUTHORIZED REPRESENTATIVE TO SIGN AND FILE A FINANCIAL ASSISTANCE APPLICATION FOR A FINANCING AGREEMENT FROM THE

STATE WATER RESOURCE CONTROL BOARD.

ATTACHMENTS:

None

RESOLUTION NO. 2025-97

**A RESOLUTION OF THE CITY COUNCIL OF THE CITY OF MCFARLAND
AUTHORIZING THE DESIGNATION OF THE CITY MANAGER AS THE AUTHORIZED
REPRESENTATIVE TO SIGN AND FILE A FINANCIAL ASSISTANCE APPLICATION FOR
A FINANCING AGREEMENT FROM THE STATE WATER RESOURCE CONTROL
BOARD.**

WHEREAS, The City of McFarland is continuing to pursue funding from the State Water Resources Control board for the planning, design and construction of the Waste Water Treatment Plant Expansion Project.

WHEREAS, One of the requirements of the funding application is to designate an Authorized representative to sign and file for and on behalf of the City a financial assistance application for a financing agreement from the state water resources control board.

WHEREAS, The City is designating the City Manager as its Authorized Representative.

WHEREAS, This Authorized Representative, is designated to provide the assurances, certifications, and commitments required for the financial assistance application, including executing a financial assistance agreement from the State Water Resources Control Board and any amendments or changes thereto.

WHEREAS, The Authorized Representative, is designated to represent the City in carrying out the City's responsibilities under the financing agreement, including certifying disbursement requests on behalf of the Entity and compliance with applicable state and federal laws.

NOW, THEREFORE, BE IT RESOLVED, by the City Council of the City of McFarland that it hereby finds and determines as follows:

1. The foregoing recitals are true and correct and incorporated herein as if set forth in full.
2. The City Council hereby approves the designation of the City Manager as its Authorized Representative to sign and file for and on behalf of the City a financial assistance application for a financing agreement from the state water resources control board.
3. This Authorized Representative, is designated to provide the assurances, certifications, and commitments required for the financial assistance application, including executing a financial assistance agreement from the State Water Resources Control Board and any amendments or changes thereto.
4. The Authorized Representative, is designated to represent the City in carrying out the City's responsibilities under the financing agreement, including certifying disbursement requests on

- behalf of the Entity and compliance with applicable state and federal laws.
- 5. The City Clerk shall certify the passage and adoption of this resolution.
- 6. This resolution is effective immediately.

PASSED AND ADOPTED at a regular meeting of the City Council of the City of McFarland on July 9, 2025 by the following vote:

	Aye	Nae	Abstain	Absent
Saul Ayon				
Ricardo Cano				
Anita Gonzalez				
María T. Pérez				
Martin Gutierrez				

CITY OF MCFARLAND

Saul Ayon, Mayor

ATTEST:

Erika De La Cruz, City Clerk

I, _____, City Clerk of the City of McFarland, California, DO HEREBY CERTIFY that the foregoing resolution is a true and accurate copy of the Resolution passed and adopted by the City Council of the City of McFarland on the date and by the vote indicated herein.

APPROVED AS TO FORM:

Nathan Hodges, City Attorney



City of McFarland

City Council Meeting

STAFF REPORT

Agenda Item No. 5.
Section: CONSENT AGENDA
Meeting Date: July 9, 2025

TO: Honorable Mayor and Council Members

FROM: Diego Viramontes, City Manager
Brian Knox, Chief of Police

SUBJECT: Approval of Resolution No. 2025-95 A RESOLUTION OF THE CITY COUNCIL OF THE CITY OF MCFARLAND AUTHORIZING THE CITY MANAGER TO EXECUTE A MEMORANDUM OF UNDERSTANDING BETWEEN THE GEO GROUP, INC. AND THE CITY OF MCFARLAND POLICE DEPARTMENT

SUMMARY:

The GEO Group, Inc. operates two private correctional facilities within McFarland city limits: the Golden State Annex and Central Valley Annex (collectively, the “McFarland Complex”). This MOU formalizes the working relationship between the McFarland Police Department (MPD) and GEO for the arrest, detention, transportation, and processing of individuals—whether private citizens or GEO employees—who commit violations of the law while on GEO property.

FINANCIAL IMPACT:

There is no fiscal impact to the City’s General Fund as the agreement provides for full cost reimbursement by GEO to the City for all police services rendered in connection with this MOU.

RECOMMENDATION:

Staff recommends the City Council adopt a resolution authorizing the City Manager to execute a Memorandum of Understanding (MOU) between the GEO Group, Inc. and the City of McFarland Police Department for the provision of police services at the Golden State Annex and Central Valley Annex facilities located in McFarland, California.

ATTACHMENTS:

1. MPD PREA MOU 2024 Revised 6-25

RESOLUTION NO. 2025-95

**A RESOLUTION OF THE CITY COUNCIL OF THE CITY OF MCFARLAND
AUTHORIZING THE CITY MANAGER TO EXECUTE A MEMORANDUM OF
UNDERSTANDING BETWEEN THE GEO GROUP, INC. AND THE CITY OF MCFARLAND
POLICE DEPARTMENT**

WHEREAS, the City of McFarland desires to maintain a collaborative and clearly defined public safety protocol with The GEO Group, Inc., which operates correctional facilities within city limits; and

WHEREAS, the Memorandum of Understanding provides for law enforcement assistance by the McFarland Police Department at the GEO Group’s facilities (Golden State Annex and Central Valley Annex) located in McFarland, California; and

WHEREAS, the MOU sets forth duties, reimbursement procedures, and coordination requirements between the parties to ensure compliance with applicable laws and to protect the health and safety of the community;

NOW, THEREFORE, BE IT RESOLVED, by the City Council of the City of McFarland that it hereby finds and determines as follows:

1. The City Council hereby approves the Memorandum of Understanding between the City of McFarland and The GEO Group, Inc., attached hereto as Exhibit A.
2. The City Manager is hereby authorized and directed to execute the Memorandum of Understanding and any related documents necessary to implement the agreement.
3. This Resolution shall become effective immediately upon adoption.

PASSED AND ADOPTED at a regular meeting of the City Council of the City of McFarland on July 9, 2025 by the following vote:

	Aye	Nae	Abstain	Absent
Saul Ayon				
Ricardo Cano				
Anita Gonzalez				
María T. Pérez				
Martin Gutierrez				

CITY OF MCFARLAND

Saul Ayon, Mayor

ATTEST:

Erika De La Cruz, City Clerk

I, _____, City Clerk of the City of McFarland, California, DO HEREBY CERTIFY that the foregoing resolution is a true and accurate copy of the Resolution passed and adopted by the City Council of the City of McFarland on the date and by the vote indicated herein.

APPROVED AS TO FORM:

Nathan Hodges, City Attorney

MEMORANDUM OF UNDERSTANDING

Between

The GEO Group, Inc.

and

McFarland Police Department

This Memorandum of Understanding (the “MOU”) is made between the City of McFarland (the “City”) and the GEO Group, Inc., a Florida Corporation (“GEO”).

RECITALS:

- A. This MOU provides for assistance between the City and GEO at GEO’s facilities known as the Golden State Annex and Central Valley Annex, in McFarland, California (individually, the “Facility” or, collectively, sometimes the “Facilities” or the “McFarland Complex.”).
- B. This MOU provides for the arrest, detention, and transportation of private citizens and GEO employees by the McFarland Police Department (the “MPD”) that have committed a violation of the law while on a Facility. It is understood the Facility Administrator who is a nonsworn employee of GEO or his or her designee will act as the liaison between the Facility and the MPD.
- C. Pursuant to the Penal Code, a correctional employee who meets the requirements as outlined in Section 830.5 is a peace officer. A peace officer’s authority to arrest extends to any place in the state while engaged in the performance of their duties in their respective employment and for the purpose of carrying out the primary function of their employment or as required under Government Code Section 8597, 8698, and 8617.

NOW, THEREFORE, the parties agree as follows:

- 1. The parties incorporate the forgoing recitals as if fully set forth herein verbatim
- 2. In the performance of any of its duties hereunder, the MPD shall be compensated for assisting in those incidents other than Critical Incidents (hereinafter described) for the cost to the MPD based on the individual officers’ pay ranges assisting in the incidents and overtime. As of the date hereof, the hourly rates range from pay for a new officer on regular duty at starting pay with full benefits to a sergeant at top step on overtime from \$36.71 to \$65.17, respectively. The forgoing pay ranges for MPD officers may be modified from time to time by the MPD by written notice to GEO. Any booking fees charged to the MPD for any arrest by

the agency operating the jail shall be paid by GEO or reimbursed to the City upon City invoicing GEO for same. The same cost to GEO shall accrue for MPD's Critical Incident services and, in addition thereto, if the patrol shift must engage with the Critical Incident and other personnel must be contacted to handle the routine shift calls for the patrol shift, GEO shall also pay for the cost of the additional personnel to perform the routine shift calls and overtime.

3. The Facility Administrator who is an employee of the GEO Group or his or her designee shall be responsible for the following occurring on any Facility.
 - a) To detain all private citizens and employees who is alleged to have committed a violation of the law while on a Facility to await the transportation to the Kern County Sheriff's Office Justice Facility located at 17801 Industrial Farm Road Bakersfield, California.
 - b) To submit copies of all paperwork (arrest report, Miranda warnings, or request for search form and criminal history report) to Kern County District Attorney's Office and referral for possible prosecution.
 - c) To gather and transfer all requested documentation the arrested citizen or employee to the arresting agency utilizing the assistance and guidance of the MPD.
 - d) To process all evidence obtained from an arrest occurring on a Facility including, but not limited to weapons, narcotics and currency.
 - e) During institutional emergencies or extraordinary circumstances, if a citizen/employee has to be arrested on institutional grounds, the institution may utilize the assistance and guidance of the MPD, to effect the arrest, transportation and processing of the citizen or employee into the Kern County Justice Receiving Facility.

4. In the event MPD handles transportation of the violators to the Kern County Central Receiving facility, MPD shall perform the following task:
 - a) All evidentiary firearms are to be seized and processed into the MPD in accordance with the MPD Policy and Procedures.
 - b) All Narcotics and drug paraphernalia shall be seized and processed into the MPD property room in accordance with MPD Policy and Procedures. All fees associated with the analysis of narcotics conducted by the Kern Criminalistic Laboratory shall be reimbursed by the GEO Group.
 - c) All currency will be seized and processed into the MPD property room in accordance with the MPD Policy and Procedures.
 - d) Dealt with subjects' vehicle or vehicle involved in a crime.

- e) Dealt with hostage situations, escapes, or riot, etc.
- 5. When the request relates to a PREA incident, Per PREA protocols, the MPD will be notified of all PREA incidents and the MPD will provide an event number documenting the notification. However, pursuant to this agreement, the MPD shall have no responsibility other than providing the event number and documenting the notification. The MPD shall have no further responsibility and shall not be responsible for further response or investigation related to such events.
- 6. GEO employees will immediately respond to the PREA or sexual assault incident in accordance with facility protocol. All appropriate parties, including Kern County Forensic Services, will be notified and the crime scene will be contained.
- 7. The term of the MOU shall retroactively begin April 1, 2024, and shall extend through April 30, 2029. This agreement supersedes any previous mutual agreement regarding the subject matter hereof.
- 8. This MOU may be terminated by either party upon no less than thirty (30) prior calendar days written notice, without cause, unless a lesser time in mutually agreed upon by both parties.
- 9. The individuals executing this agreement on behalf of each party attests that he/she is authorized to execute the agreement on behalf of their respective agencies and that the agency will be bound by the terms and conditions herein.
- 10. The MPD will conduct investigations on all traffic accidents that occur on the Facilities. Additionally, the Police Department has agreed to assist with traffic control in the areas surrounding institutional property when deemed necessary during emergencies as decided by the Chief of Police. The City of McFarland will be compensated for its support, as indicated in section C, item no. 2 of this MOU.
- 11. This agreement will enhance the harmonious working relationship established between the MPD and the Golden State Annex and Central Valley Annex.
- 12. MOU
 - a) This Agreement shall be governed by and construed in accordance with the laws of the State of California.
 - b) The captions appearing in this Agreement are for convenience only, are not part of this Agreement, and shall be considered in interpreting this Agreement.
 - c) This Agreement constitutes the entire agreement between the parties with regard to the subject matter herein and supersedes all prior oral and written agreements and understanding between the parties with respect thereto.

- d) In the event any action or proceeding is instituted arising out of or relating to this Agreement, the prevailing party shall be entitled to its reasonable attorneys' fees and actual costs.
- e) Waiver by a party of any provision of this Agreement shall not be considered a continuing waiver or a waiver of any other provision, including the time for performance of any such provision.
- f) This Agreement shall be binding upon and shall inure to the benefit of the parties hereto, and their respective heirs, successors, and assigns.
- g) GEO and MPD acknowledge that each party and their respective legal counsel have reviewed this Agreement and agree that this Agreement is the product of negotiations between the parties. This Agreement shall be interpreted without reference to the rule of interpretation of documents that uncertainties or ambiguities therein shall be determined against the party so drafting the Agreement.

NOW THEREFORE, the parties have executed this Memorandum of Understanding to be effective on April 1st , 2024.

Brian Knox
Chief of Police
Mc Farland Police Department

T. Andrews
Facility Administrator
Golden State Annex

Diego Viramontes
City Manager
City of McFarland

Scott Frauenheim
Scott Frauenheim (Jun 25, 2025 15:28 PDT)

S. Frauenheim
Facility Administrator
Central Valley Annex

Sul
Saul Ayon (Jun 27, 2025 10:14 PDT)

Saul Ayon
City Mayor
City of McFarland



City of McFarland

City Council Meeting

STAFF REPORT

Agenda Item No. 6.
Section: CONSENT AGENDA
Meeting Date: July 9, 2025

TO: Honorable Mayor and Council Members

FROM: Diego Viramontes, City Manager
Megan Snyder, Community Development Director
Meliza Rosa, Grant Manager

SUBJECT: Approval of Resolution No. 2025-96 A RESOLUTION OF THE CITY COUNCIL OF THE CITY OF MCFARLAND AUTHORIZING THE FILING OF AN APPLICATION FOR CONGESTION MITIGATION AIR QUALITY PROGRAM FUNDING AND COMMITTING THE NECESSARY LOCAL MATCH AND STATING THE ASSURANCE TO COMPLETE THE PROJECT

SUMMARY:

The Congestion Mitigation and Air Quality (CMAQ) program provides funding for transportation projects or programs that will contribute to attainment or maintenance of the national ambient air quality standards. The CMAQ program supports two important goals of the Department of Transportation: improving air quality and relieving congestion.

As the City of McFarland has recently acquired a vacant lot at the northeast corner of Taylor and Mast Avenues, we selected this site strategically for a Park and Ride facility that will serve commuters and regional transit users.

The proposed project supports regional goals for improving air quality, reducing greenhouse gas emissions, and promoting multimodal transportation options by facilitating carpooling, vanpooling, and future transit access.

This project application is for \$3,086,000 and our local match is 11.47% of total project cost, equaling \$353,964.20.

FINANCIAL IMPACT:

If awarded, the City of McFarland would receive \$3,086,000 and our Local Match would be \$353,964.20 from the General Fund.

RECOMMENDATION:

Staff recommends approval of Resolution 2025-96 authorizing the City's application to the Congestion Mitigation Air Quality Program.

ATTACHMENTS:

1. Park and Ride Project Cost Estimate

2. 2025-CMAQ-Application-Package

RESOLUTION NO. 2025-96

A RESOLUTION OF LOCAL SUPPORT OF THE CITY COUNCIL OF THE CITY OF MCFARLAND AUTHORIZING THE FILING OF AN APPLICATION FOR CONGESTION MITIGATION AIR QUALITY PROGRAM FUNDING AND COMMITTING THE NECESSARY LOCAL MATCH AND STATING THE ASSURANCE TO COMPLETE THE PROJECT

WHEREAS, The City of McFarland (herein referred to as APPLICANT) is submitting an application to the Kern Council of Governments (Kern COG) for \$3,086,000 in funding from the Congestion Mitigation Air Quality Program (herein referred to as “federal funding”) for the Connected Commutes: McFarland Park and Ride Initiative (herein referred to as PROJECT); and

WHEREAS, APPLICANT has the financial capacity to complete, operate and maintain the project; and

WHEREAS, APPLICANT will ensure that funds required from other sources will be reasonably expected to be available on the time frame needed to carry out the project; and

WHEREAS, APPLICANT is authorized to execute and file an application for funding the PROJECT under the Congestion Mitigation Air Quality Program; and

NOW, THEREFORE, BE IT RESOLVED, by the City Council of the City of McFarland that it hereby finds and determines as follows:

1. APPLICANT will provide \$353,964.20 in local matching funds; and
2. APPLICANT understands that the Congestion Mitigation Air Quality Program funding for the project is fixed at the approved programmed amount, and that any cost increases must be funded by the APPLICANT from other funds, and that APPLICANT does not expect any cost increases to be funded with additional federal funding; and
3. APPLICANT understands the funding deadlines associated with these funds and will comply with the program implementation procedures described in Chapter 2 of the Kern COG Project Delivery Policies and Procedures manual; and
4. PROJECT will be implemented as described in the complete application and in this resolution and, if approved, for the amount programmed in the FTIP; and
5. APPLICANT and the PROJECT will comply with the requirements as set forth in the program; and
6. APPLICANT authorizes its Executive Director, General Manager, or designee to execute and file an application with Kern COG for federal funding for the PROJECT as referenced in this resolution.

PASSED AND ADOPTED at a regular meeting of the City Council of the City of McFarland on July 9, 2025 by the following vote:

	Aye	Nae	Abstain	Absent
Saul Ayon				
Ricardo Cano				
Anita Gonzalez				
María T. Pérez				
Martin Gutierrez				

CITY OF MCFARLAND

Saul Ayon, Mayor

ATTEST:

Erika De La Cruz, City Clerk

I, _____, City Clerk of the City of McFarland, California, DO HEREBY CERTIFY that the foregoing resolution is a true and accurate copy of the Resolution passed and adopted by the City Council of the City of McFarland on the date and by the vote indicated herein.

APPROVED AS TO FORM:

Nathan Hodges, City Attorney



**Kern Council
of Governments**

March 21, 2025

TO: Member Agencies and Interested Persons

FROM: AHRON HAKIMI,
EXECUTIVE DIRECTOR

By: Ceasar Valle,
Regional Planner

SUBJECT: **Congestion Mitigation and Air Quality (CMAQ) Program
Call for Projects Application Package**

On March 20, 2025, the Kern Council of Governments' (Kern COG) Board of Directors approved a Congestion Mitigation and Air Quality (CMAQ) Program call for projects. The following items have been assembled to assist member agency staff and interested persons applying for CMAQ funding. Please see attachments for more details.

- **Project Application** – The application and instructions are enclosed. The application package is available on the Kern COG website at www.kerncog.org/call-for-projects/. **CMAQ Program project applications are due by 5:00 PM on Thursday, July 17, 2025.** Please submit completed application with transmittal letter on agency letterhead to:

Attn: Ceasar Valle
Kern Council of Governments
1401 19th St., Suite 300
Bakersfield, CA 93301

Send electronically: digitally [Via Dropbox link](#) OR via mail on flash drive

- **CMAQ Program Policy and Procedure** – Each CMAQ project must meet three basic criteria: it must be a transportation project; it must be in or benefit a nonattainment or maintenance area; and it must generate an emissions reduction. CMAQ funds are reimbursable federal aid funds, subject to the requirements of Title 23, United States code. Eligible costs for funds under this program includes preliminary engineering, right-of-way acquisition, capital costs, and construction costs associated with an eligible activity. If there are any questions regarding eligibility and agency sponsorship, please contact Kern COG staff.
- **CMAQ: Local Cost-Effectiveness Policy** – As part of the development of local air quality measures for the 8-hour Ozone Plan, the San Joaquin Valley COG's acting in their role as Federal Metropolitan Planning Organizations (MPOs) developed a process across the Valley for distributing 20% of the CMAQ funds to projects that meet a minimum cost-effectiveness.

Kern Council of Governments

1401 19th Street, Suite 300, Bakersfield, CA 93301 (661) 635-2900 Facsimile (661) 324-8215 TTY (661) 832-7433 www.kerncog.org

- **Emission Reduction Calculation Resource** – The “Methods to Find the Cost-Effectiveness of Funding Air Quality Projects” tool is the standard for calculating emissions reductions. Please provide documentation of emission input data for each application. For more information, visit <https://ww2.arb.ca.gov/resources/documents/congestion-mitigation-and-air-quality-improvement-cmaq-program>. For projects to pave unpaved roads and shoulders, use spreadsheets provided on the Kern COG website www.kerncog.org/call-for-projects/ to calculate PM10 emission reductions.
- **Carbon Reduction Program** – This cycle, projects for the Carbon Reduction Program (CRP) funds will be selected following the CMAQ Policy and Procedure. The state developed a Carbon Reduction Strategy with three pillars: 1. Zero-Emission Vehicles & Infrastructure, 2. Active Transportation & Micromobility, and 3. Rail & Transit. This information is posted at the Caltrans Carbon Reduction Program website <https://dot.ca.gov/programs/esta/carbon-reduction>. All pillars are eligible activities under the CMAQ Policy and Procedure.
- **Local Agency Adopted Resolution** – A resolution where a commitment is made to fund and implement projects as described in application is required.
- **Air District Grant Programs** – The Eastern Kern Air Pollution Control District Grants website is http://www.kernair.org/Main_Pages/grants.html. The San Joaquin Valley Air Pollution Control District’s Grants and Incentives website is <http://valleyair.org/grants/>. These grants should be considered for matching purposes or to fund an entire project.
- **Timeline** – In January 2026, a final draft CMAQ Program of Projects will be submitted to the Transportation Technical Advisory Committee and the Transportation Planning Policy Committee for their review. In February 2026, if the CMAQ Program of Projects is approved, these projects will be amended into the 2025 Federal Transportation Improvement Program (FTIP) and introduced into the Draft 2027 FTIP.
- **Proposed Project Review Office Hours** – Kern COG staff will be available by appointment April 21st – May 1st to review proposed project(s). Email cvalle@kerncog.org by April 14th to set up an appointment. Kern COG staff will provide project development and submittal assistance.

Should you have any questions, specifically regarding eligibility, please contact:

Raquel Pacheco at 661-635-2907 or rpacheco@kerncog.org

Cesar Valle at 661-635-2917 or cvalle@kerncog.org

Enclosures:

- CMAQ Project Application
- CMAQ Project Application Instructions
- CMAQ Program Policy and Procedure
- CMAQ: Local Cost-Effectiveness Policy
- Sample Local Agency Resolution

KERN COUNCIL OF GOVERNMENTS
Congestion Mitigation and Air Quality (CMAQ) Program
PROJECT APPLICATION – Due Thursday, July 17, 2025

*Please note this is a PDF fillable form so responses may be typed. Items 1, 2, 7, and 22 are drop downs. Totals in item 6 will automatically calculate.

- (1) Is the project included in a local agency-adopted resolution supporting the project? YES NO
- (2) Does the proposed project meet basic eligibility requirements? YES NO
- (3) Project background and justification: Explain the project in terms of the existing infrastructure, its impact for service, safety or any other issue that is relevant to the project (attach to application). If the project scope relates to fueling infrastructure please provide a 3-year fleet conversion plan.
- (4) Lead Agency: _____
- (5) Project description [(Location:) + (Limits) + (;) + (Improvement/Activity)]

(6)	Funding Type	PE	R/W	Const.	Total
	Local	\$ _____	\$ _____	\$ _____	\$ _____
	Local	\$ _____	\$ _____	\$ _____	\$ _____
	State	\$ _____	\$ _____	\$ _____	\$ _____
	Federal	\$ _____	\$ _____	\$ _____	\$ _____
	Total	\$ _____	\$ _____	\$ _____	\$ _____

- (7) Programming Year by Phase: PE: _____ R/W: _____ Const: _____
- (8) VMT Reduction (annual miles): _____
- (9) VOC Reduction (kg/day): _____ Additional documentation required. See instructions.
- (10) NOx Reduction (kg/day): _____ Additional documentation required. See instructions.
- (11) PM₁₀ Reduction (kg/day): _____ Additional documentation required. See instructions.
- (12) PM_{2.5} Reduction (Kg/day): _____ Additional documentation required. See instructions.
- (13) CO Reduction (kg/day): _____ Additional documentation required. See instructions.
- (14) Cost-Effectiveness (\$/lb): _____ Additional documentation required. See instructions.
- (15) Livability and Safety: Describe how project provides the six benefits; limit to half page per benefit.
- (16) Hwy Peak Period LOS Before Project (AM/PM average): _____
- (17) Hwy Peak period LOS After Project (AM/PM average): _____
- (18) Bikeway Peak Period LOS Before Project (AM/PM average): _____
- (19) Bikeway Peak period LOS After Project (AM/PM average): _____
- (20) Pedestrian Peak period LOS Before Project (AM/PM average): _____
- (21) Pedestrian Peak period LOS After Project (AM/PM average): _____
- (22) Is the project identified as a RACM/BACM? YES NO

Application completed by: _____ Date Completed: _____

E-mail: _____ Phone Number: _____

Agency: _____

Address: _____

Send completed application electronically on a flash drive with transmittal letter on agency letterhead to:
 Attn: Ceasar Valle ❖ Kern Council of Governments, 1401 19th Street, Suite 300, Bakersfield, CA 93301
OR send Digitally via [Dropbox, click here.](#)

KERN COUNCIL OF GOVERNMENTS
Congestion Mitigation and Air Quality (CMAQ) Program – Call for Projects
2025 PROJECT APPLICATION INSTRUCTIONS

1. Resolution requirement – All projects submitted for funding must be included in a local agency-adopted resolution where a commitment is made to fund and implement projects as described in applications. A sample resolution is provided. When submitting multiple CMAQ project applications, all CMAQ projects may be included in one CMAQ resolution. Please include Carbon Reduction Program if applicable.
2. Eligibility requirements – Chapter 5 of the Kern COG Project Delivery Policies and Procedures manual provides information regarding eligible projects funded in the CMAQ program. Please review those eligibility guidelines. Should there be any question about project eligibility, Kern COG staff should be consulted prior to submittal.

Carbon Reduction Strategy - Projects for the Carbon Reduction Program (CRP) funds will be selected following the CMAQ Policy and Procedure. The state developed a Carbon Reduction Strategy with three pillars: 1. Zero-Emission Vehicles & Infrastructure, 2. Active Transportation & Micromobility, and 3. Rail & Transit. Information posted at the Caltrans CRP website <https://dot.ca.gov/programs/esta/carbon-reduction>. All pillars are eligible activities under the CMAQ Policy and Procedure.

3. Project background and justification - A purpose and need statement for the project, no longer than one page. Provide relevant information about the need for the project, recent history, safety issues, air quality benefits or any other information that relates the project to the agency's transportation goals, air quality commitments, etc.
4. Lead agency - The lead agency is the same agency that will be responsible for delivering the project. That agency will require a Master Agreement with Caltrans to participate in the federal-aid reimbursement process.
5. Project description – The project description should provide information related to the limits and length, intersection location, transit vehicle description in terms of passenger size and fuel/engine type, replacement stock or new service, and route/corridor service information. Example: (Location:) + (Limits) + (;) + (Improvement/Activity)
6. Funding information – Funding type refers to revenue source description such as: general fund, impact fee, Transportation Development Act (TDA), etc. The funding chart is broken into local, state, and federal funding rows, by phase: PE is preliminary engineering; R/W is rights-of-way; and Const is construction. Transit projects may use the const. phase to indicate their amounts for capital costs. **The Local match requirement for CMAQ/CRP funding is 11.47%.** This is the minimum amount of local match required for a CMAQ/CRP project. Should your agency choose to increase the local match percentage in the proposed project, indicate that in the table as well. Federal-aid funding may be matched with local and state funds.
7. Programming year – Projects will be programmed either in federal fiscal year 26/27 or 27/28. The federal fiscal year begins October 1 each year and ends on September 30th of the following year. It is imperative that a project be initiated and obligated during the year in which it is programmed. For more information, please see Chapter 2 Implementation Procedures Overview of the Kern COG Project Delivery Policies and Procedures available at www.kerncog.org/call-for-projects/.

KERN COUNCIL OF GOVERNMENTS
Congestion Mitigation and Air Quality (CMAQ) Program – Call for Projects
2025 PROJECT APPLICATION INSTRUCTIONS

8. Through 21.

VMT REDUCTION and EMISSIONS BENEFIT CALCULATIONS:

Use the “Methods to Find the Cost Effectiveness of Funding Air Quality Projects” document from the California Air Resources Board in Cooperation with Caltrans and CAPCOA, or “Automated Cost-effectiveness Calculation Tool” (Microsoft Access), available at <https://ww2.arb.ca.gov/resources/documents/congestion-mitigation-and-air-quality-improvement-cmaq-program>, or the updated version. Kern COG staff shall be consulted prior to the application deadline to determine if an alternative analysis program or formula should be used outside the Air Resources Board air quality emission calculation tools. Otherwise all applications are expected to use the appropriate ARB calculator / formulas.

- The project scope should be described in terms of current conditions and conditions after the project is completed. This information should then support the technical assumptions for the project.
- Technical assumptions about the project should be provided in detail and include quantity and metrics for use in the emissions calculations. Information should be provided for the “before” scenario and “after” scenario.
- The emissions calculation formula used should be written out to facilitate verification and accuracy.
- References to emissions tables used should be provided as necessary to facilitate verification and accuracy.

14. COST BENEFIT CALCULATION - Should there be an issue with finding an appropriate calculator for emissions benefits calculations or the cost benefit calculator, Kern COG staff should be consulted prior to the application deadline to allow for appropriate assistance to member agency staff. Kern COG staff should be able to verify output, the formula used and data used in order for the application to be ranked.

15. LIVABILITY AND SAFETY - Describe whether and how the project provides the six listed livability or safety benefits; provide no more than a half page response for each benefit. The four Livability benefits are: (1) Will enhance or reduce the average cost of user mobility through the creation of more convenient transportation options for travelers; (2) Will improve existing transportation choices by enhancing points of modal connectivity, increasing the number of modes accommodated on existing assets, or reducing congestion on existing modal assets; (3) Will improve travel between residential areas and commercial centers and jobs; (4) Will improve accessibility and transportation services for economically disadvantaged populations, non-drivers, senior citizens, and persons with disabilities, or make goods, commodities, and services more readily available to these groups. The two Safety benefits are: (5) Is the existing Accident Rate higher than the average rate for a similar facility, and does the project reduce the Accident Rate to the average rate or lower? Yes or No and if yes, provide rates and supporting documentation; and (6) Is the existing Fatality Rate higher than the average rate for a similar facility, and does the project reduce the Fatality Rate to the average rate or lower? Yes or No and if yes, provide rates and supporting documentation.

16. through 21. – Provide peak period Level of Service (LOS) for intersection(s) and/or road segments within the project limits for existing conditions (Before LOS) and estimated LOS after project completion (After LOS). If applicable, provide Bikeway and/or Pedestrian LOS. If LOS varies within the project limits, provide a weighted average. LOS should be calculated using methods consistent with the Highway Capacity Manual.

KERN COUNCIL OF GOVERNMENTS
Congestion Mitigation and Air Quality (CMAQ) Program – Call for Projects
2025 PROJECT APPLICATION INSTRUCTIONS

22. Is the project identified as a RACM/BACM? Please contact Kern COG staff to determine if the proposed project is a Reasonably Available Control Measure (RACM) or a Best Available Control Measure (BACM).
23. In order to be eligible to receive points, application criteria must be complete. If criteria do not apply, state N/A. The Kern COG CMAQ Policy requires that calculations be consistently used for all applications. To assure this consistency, additional documentation is required to allow for verification of the methodology, data and output.
24. Send completed application electronically on a flash drive with transmittal letter on agency letterhead to:
Attn: Ceasar Valle, Kern Council of Governments, 1401 19th Street, Suite 300, Bakersfield, CA 93301
OR send digitally via [Dropbox, click here](#).

If there are any questions about information in the application or these instructions, please contact:

Raquel Pacheco at 661-635-2907 or rpacheco@kerncog.org

Ceasar Valle at 661-635-2917 or cvalle@kerncog.org



City of McFarland

City Council Meeting

STAFF REPORT

Agenda Item No. 7.
Section: CONSENT AGENDA
Meeting Date: July 9, 2025

TO: Honorable Mayor and Council Members

FROM: Diego Viramontes, City Manager
Yerlys Hernandez, Public Works Director

SUBJECT: Approval of Resolution No. 2025-93 A RESOLUTION OF THE CITY COUNCIL OF THE CITY OF MCFARLAND APPROVING THE AUTHORIZATION TO SUBMIT A REGIONAL SURFACE TRANSPORTATION (RSTP) APPLICATION TO KERN COG FOR THE REHABILITATION OF W. PERKINS AVENUE FROM 5TH STREET TO FRONTAGE ROAD

SUMMARY:

Kern COG has issued a call for projects for federal RSTP grant funds. These funds can be used to improve federally classified streets, which include major roads such as collectors and arterial streets. Kern COG provides fair-share funding to each local agency based on population. For the 2025 Call for Projects, McFarland's fair share is \$478,000, with a minimum required local match of 11.47% of the total project cost.

City staff has identified W. Perkins Ave., from Garzoli Ave. to Frontage Rd., as the top candidate for this grant funding. City Staff proposes to divide the project into two (2) sections: a Base Bid and Bid Option 1. The proposed rehabilitation for both phases includes grinding and removing the existing asphalt pavement to a depth of 3 inches, followed by installation of a 3-inch hot mix asphalt overlay. The scope also includes roadway striping, utility adjustments to match the new pavement grade, and upgrades to ADA ramps at various intersections and alleys within the project limits. Upon completion, the roadway will be restored to an acceptable level of service.

The Base Bid covers approximately 1,400 feet—from 5th Street to Frontage Road—excluding the previously rehabilitated intersection at W. Perkins Avenue and 3rd Street, which was completed as part of the 2023 RSTP funding. If construction bids are favorable, the City intends to proceed with Bid Option 1, extending the project limits westward as far as funding allows, potentially up to Garzoli Avenue—a total additional length of approximately 2,050 feet.

Kern COG policy requires that local agencies adopt a resolution confirming their willingness and ability to provide the local match and deliver the project. The plan is to request preliminary engineering in fiscal year 2026/27, with construction scheduled for fiscal year 2027/28.

FINANCIAL IMPACT:

The estimated project cost including environmental, design, construction management, and construction for the base bid is \$549,790 with a Federal match of \$478,000 and a local match of \$71,790 from TDA Funds.

RECOMMENDATION:

Staff recommends that the City Council adopt Resolution No. 2025-93 a resolution authorizing the City Manager and or Public Works Director to complete and execute an application with Kern COG for Regional Surface Transportation (RSTP) funding for the W. Perkins Ave. Rehabilitation from 5th St. to Frontage Rd

ATTACHMENTS:

1. 2025 RSTP Call for Projects - W Perkins - Project SITE MAP
2. 2025 RSTP Call for Projects - W Perkins - ENG Estimate - 7-02-25

RESOLUTION NO. 2025-93

**A RESOLUTION OF THE CITY COUNCIL OF THE CITY OF MCFARLAND
AUTHORIZING THE FILING OF AN APPLICATION FOR REGIONAL SURFACE
TRANSPORTATION PROGRAM (RSTP) PROGRAM FUNDING AND COMMITTING THE
NECESSARY LOCAL MATCH AND STATING THE ASSURANCE TO COMPLETE THE
PROJECT.**

WHEREAS, the City of McFarland is a municipal corporation duly created and existing pursuant to the Constitution and laws of the State of California; and

WHEREAS, the City of McFarland (herein referred to as APPLICANT) is submitting an application to the Kern Council of Governments (Kern COG) for \$478,000 in funding from the RSTP Program for the W. Perkins Ave. Rehabilitation from Garzoli Ave. to Frontage Rd. (herein referred to as PROJECT); and

WHEREAS, the project will be divided into two (2) sections: a Base Bid and Bid Option 1; and

WHEREAS, Base Bid covers from 5th Street to Frontage Road, and Bid Option 1, will extend the project limits westward as far as funding allows, from 5th St Street to Garzoli Avenue; and

WHEREAS, the APPLICANT has the financial capacity to complete, operate, and maintain the project; and

WHEREAS, the APPLICANT will ensure that funds required from other sources will be reasonably expected to be available on the time frame needed to carry out the project; and

WHEREAS, the APPLICANT is authorized to execute and file an application for funding the PROJECT under the Regional Surface Transportation Program (RSTP); and

NOW, THEREFORE, BE IT RESOLVED, by the City Council of the City of McFarland that it hereby finds and determines as follows:

1. APPLICANT will provide \$71,790 minimum match amount in local matching funds; and
2. APPLICANT understands that the RSTP funding for the project is fixed at the approved programmed amount, and that any cost increases must be funded by the APPLICANT from other funds, and that

APPLICANT does not expect any cost increases to be funded with additional RSTP funding; and

3. APPLICANT understands the funding deadlines associated with these funds and will comply with the program implementation procedures described in Chapter 2 of the Kern COG Project Delivery Policies and Procedures manual; and

4. PROJECT will be implemented as described in the complete application and in this resolution and, if approved, for the amount programmed in the Federal Transportation Improvement Program (FTIP); and

5. APPLICANT and the PROJECT will comply with the requirements as set forth in the program; and

6. APPLICANT authorizes its Executive Director, General Manager, or designee to execute and file an application with Kern COG for RSTP funding for the PROJECT as referenced in this resolution.

PASSED AND ADOPTED at a regular meeting of the City Council of the City of McFarland on July 9, 2025 by the following vote:

	Aye	Nae	Abstain	Absent
Saul Ayon				
Ricardo Cano				
Anita Gonzalez				
María T. Pérez				
Martin Gutierrez				

CITY OF MCFARLAND

Saul Ayon, Mayor

ATTEST:

Erika De La Cruz, City Clerk

I, _____, City Clerk of the City of McFarland, California, DO HEREBY CERTIFY that the foregoing resolution is a true and accurate copy of the Resolution passed and adopted by the City Council of the City of McFarland on the date and by the vote indicated herein.

APPROVED AS TO FORM:

Nathan Hodges, City Attorney

KERN COUNCIL OF GOVERNMENTS
Regional Surface Transportation Program (RSTP)
2025 PROJECT APPLICATION

CITY OF McFARLAND – W. PERKINS AVE. REHABILITATION – SITE MAP

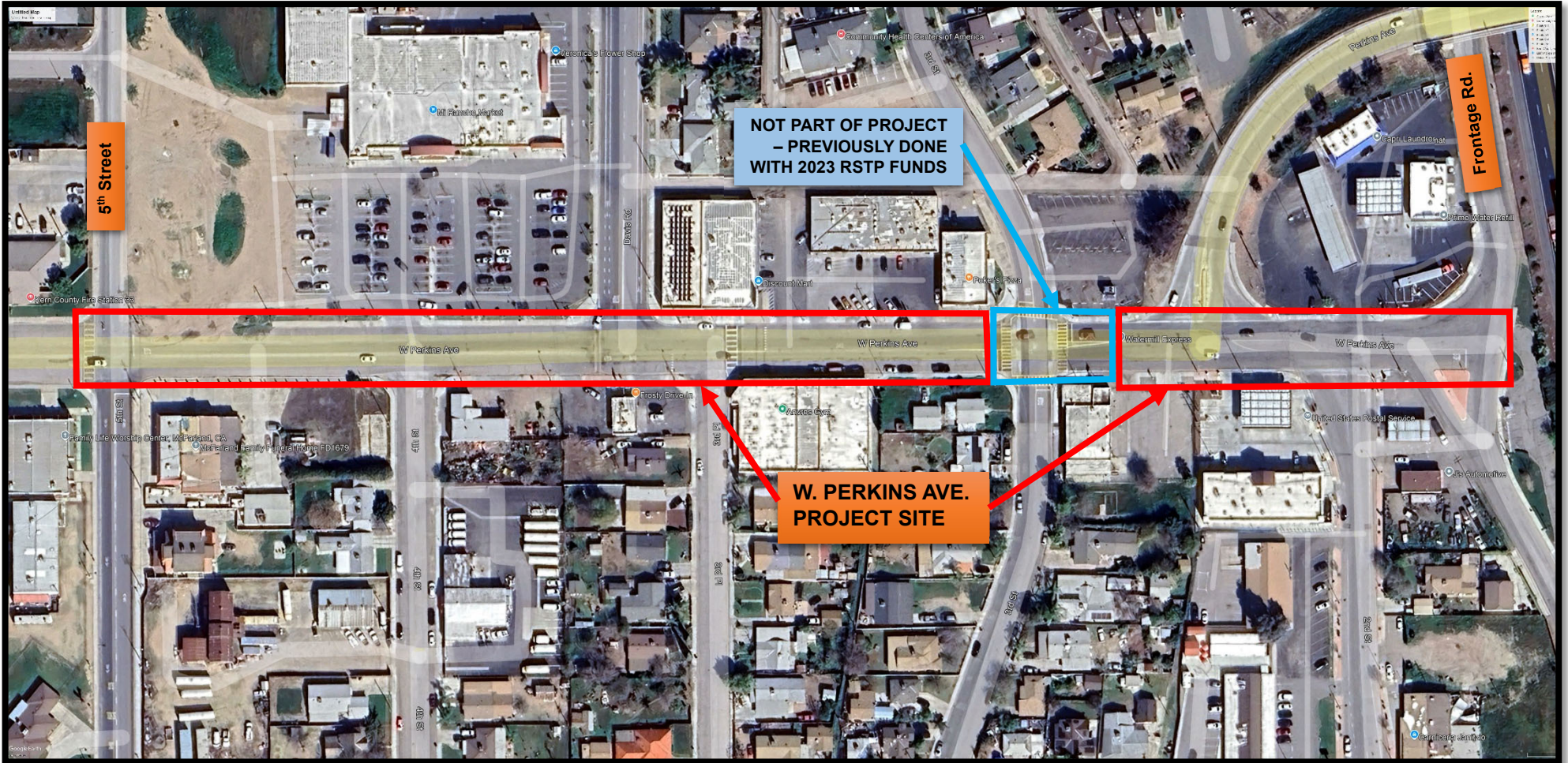

City of McFarland
2025 RSTP CALL FOR PROJECTS
BASE BID
W PERKINS AVE. REHABILITATION FROM 5TH ST. TO FRONTAGE RD.
PRELIMINARY ENGINEER'S ESTIMATE

BASE BID

ITEM NO.	ITEM CODE	UNIT OF MEASURE	ESTIMATED QUANTITY	PRICE PER UNIT	TOTAL PRICE
1	SITE DEMOLITION, CUT & HAUL EXCESS MATERIAL	L.S.	1	\$ 40,000.00	\$ 40,000.00
2	COLD PLANE 3-INCH EXISTING AC SURFACE, HAUL-OFF	S.F.	68350	\$ 0.60	\$ 41,010.00
3	TYPE "A" HOT MIX ASPHALT	TON	1377	\$ 126.00	\$ 173,502.00
4	INSTALL 8" THICK CONCRETE CROSS GUTTER/APRON (INCLUDES SAWCUT, LAYOUT, DEMOLITION OF EXISTING IMPROVEMENTS)	S.F.	505	\$ 30.00	\$ 15,150.00
5	CLASS 2 AGGREGATE BASE - UNDER NEW X-GUTTER	TON	39	\$ 150.00	\$ 5,850.00
6	INSTALL 12" SOLID LIMIT/CROSSWALK LINE - THERMOPLASTIC	L.F.	172	\$ 9.00	\$ 1,548.00
7	INSTALL 24" SOLID CROSSWALK LINE - THERMOPLASTIC	L.F.	99	\$ 20.00	\$ 1,980.00
8	INSTALL 6" YELLOW CENTER LINE (DETAIL 2) - THERMOPLASTIC	L.F.	188	\$ 6.00	\$ 1,128.00
9	INSTALL 6" YELLOW CENTER LINE (DETAIL 22) - THERMOPLASTIC	L.F.	984	\$ 7.00	\$ 6,888.00
10	INSTALL 8" WHITE CHANNALIZING LINE (DETAIL#) - THERMOPLASTIC	L.F.	75	\$ 8.00	\$ 600.00
11	INSTALL WHITE THERMOPLASTIC PAVEMENT MARKINGS	S.F.	176	\$ 14.00	\$ 2,464.00
12	FURNISH AND INSTALL SOLAR-POWERED FLASHING LED STOP SIGN - R1-1 (30"X30")	EA.	1	\$ 3,500.00	\$ 3,500.00
13	ADJUST MONUMENT COVER TO GRADE	EA.	5	\$ 1,750.00	\$ 8,750.00
14	ADJUST WATER VALVE COVER TO GRADE	EA.	4	\$ 1,650.00	\$ 6,600.00
15	ADJUST MANHOLE COVER TO GRADE	EA.	3	\$ 1,650.00	\$ 4,950.00
16	FURNISH AND INSTALL BLUE RETROREFLECTIVE FIRE HYDRANT MARKER	EA.	3	\$ 50.00	\$ 150.00
17	QUALITY CONTROL PROGRAM	L.S.	1	\$ 4,000.00	\$ 4,000.00
18	PREPARE AND IMPLEMENT STORMWATER SOILS LOSS PREVENTION PLAN	L.S.	1	\$ 4,000.00	\$ 4,000.00
19	PREPARE AND IMPLEMENT TEMPORARY TRAFFIC CONTROL PLAN	L.S.	1	\$ 40,000.00	\$ 40,000.00

Date: 07/01/25

By: JMP

Construction BASE BID Subtotal: \$ 362,070.00

Contingency (10%): \$ 36,210.00

Construction Engineering: \$ 59,740.00

CONSTRUCTION TOTAL: \$ 458,020.00

Advertisement: \$ 1,500.00

Preliminary Engineering & Environmental: \$ 90,270.00

BASE BID Total Cost: \$ 549,790.00

City of McFarland
2025 RSTP CALL FOR PROJECTS
BID OPTION 2
W PERKINS AVE. REHABILITATION FROM GARZOLI AVE. TO 5TH ST.
PRELIMINARY ENGINEER'S ESTIMATE

ITEM NO.	ITEM CODE	UNIT OF MEASURE	ESTIMATED QUANTITY	PRICE PER UNIT	TOTAL PRICE
1	SITE DEMOLITION, CUT & HAUL EXCESS MATERIAL	L.S.	1	\$ 25,000.00	\$ 25,000.00
2	COLD PLANE 3-INCH EXISTING AC SURFACE, HAUL-OFF	S.F.	140000	\$ 0.30	\$ 42,000.00
3	TYPE "A" HOT MIX ASPHALT	TON	2821	\$ 115.00	\$ 324,415.00
4	INSTALL 8" THICK CONCRETE CROSS GUTTER/APRON (INCLUDES SAWCUT, LAYOUT, DEMOLITION OF EXISTING IMPROVEMENTS)	S.F.	1300	\$ 25.00	\$ 32,500.00
5	CLASS 2 AGGREGATE BASE - UNDER NEW X-GUTTER	TON	100	\$ 60.00	\$ 6,000.00
6	INSTALL 12" SOLID LIMIT/CROSSWALK LINE - THERMOPLASTIC	L.F.	248	\$ 7.00	\$ 1,736.00
7	INSTALL 24" SOLID CROSSWALK LINE - THERMOPLASTIC	L.F.	110	\$ 19.00	\$ 2,090.00
8	INSTALL 6" YELLOW CENTER LINE (DETAIL 2) - THERMOPLASTIC	L.F.	1430	\$ 5.00	\$ 7,150.00
9	INSTALL 6" YELLOW CENTER LINE (DETAIL 22) - THERMOPLASTIC	L.F.	400	\$ 6.00	\$ 2,400.00
10	INSTALL 8" WHITE CHANNALIZING LINE (DETAIL#) - THERMOPLASTIC	L.F.	885	\$ 7.00	\$ 6,195.00
11	INSTALL WHITE THERMOPLASTIC PAVEMENT MARKINGS	S.F.	258	\$ 12.00	\$ 3,096.00
12	FURNISH AND INSTALL SOLAR-POWERED FLASHING LED STOP SIGN - R1-1 (30"X30")	EA.	1	\$ -	\$ -
13	ADJUST MONUMENT COVER TO GRADE	EA.	1	\$ 1,750.00	\$ 1,750.00
14	ADJUST WATER VALVE COVER TO GRADE	EA.	18	\$ 1,600.00	\$ 28,800.00
15	ADJUST MANHOLE COVER TO GRADE	EA.	12	\$ 1,600.00	\$ 19,200.00
16	FURNISH AND INSTALL BLUE RETROREFLECTIVE FIRE HYDRANT MARKER	EA.	3	\$ 50.00	\$ 150.00
17	QUALITY CONTROL PROGRAM	L.S.	1	\$ 3,500.00	\$ 3,500.00
18	PREPARE AND IMPLEMENT STORMWATER SOILS LOSS PREVENTION PLAN	L.S.	1	\$ 3,000.00	\$ 3,000.00
19	PREPARE AND IMPLEMENT TEMPORARY TRAFFIC CONTROL PLAN	L.S.	1	\$ 30,000.00	\$ 30,000.00

Date: 07/01/25

By: JMP

Construction BID Option 1 Subtotal: \$ 538,982.00

Contingency (10%): \$ 53,900.00

Construction Engineering: \$ 59,290.00

CONSTRUCTION TOTAL: \$ 652,172.00

Advertisement: \$ -

Preliminary Engineering & Environmental: \$ -

BID Option 1 Total Cost: \$ 652,172.00



City of McFarland

City Council Meeting

STAFF REPORT

Agenda Item No. 8.
Section: CONSENT AGENDA
Meeting Date: July 9, 2025

TO: Honorable Mayor and Council Members

FROM: Diego Viramontes, City Manager
Yerlys Hernandez , Public Works Director

SUBJECT: Approval of Resolution No. 2025-94 A RESOLUTION OF THE CITY COUNCIL APPROVING THE COST FOR REPAIR OF THE ELGIN STREET SWEEPER AND AUTHORIZING THE USE OF ALLOCATED FUNDS

SUMMARY:

In January 2025, the City's Elgin Air Sweeper began experiencing multiple mechanical issues, resulting in repeated breakdowns. While minor repairs were made to keep the unit temporarily operable, further diagnostics revealed that extensive repairs are now required.

The primary issue involves the rear blower fan turbine, which has become significantly unbalanced due to wear over time. This imbalance has caused excessive vibration throughout the vehicle's chassis. As a result, the vibrations have led to mounting electrical failures and further stress on critical mechanical systems, rendering the sweeper unreliable and increasingly costly to operate without major repairs.

The sweeper is an essential asset for the City, especially for scheduled street cleaning, debris removal, and stormwater system protection. Its continued malfunction directly impacts the City's ability to maintain clean and safe public infrastructure.

Although funding for street sweeper repairs is already included in the adopted Fiscal Year 2025–26 budget, the condition of the sweeper and the urgency of maintaining clean streets and safe roadways compel staff to act promptly. Staff therefore requests approval to proceed immediately with repairs using the already allocated funds.

Staff attempted to get multiple quotes for repairs of the Sweeper, but Haaker, the manufacturer of the Sweeper has proprietary parts that only they can source and supply. Per section 2.24.070 sub section E - Purchasing Methods of the Municipal Code, Commodities which can be obtained from only one lender as determined by the City are exempt from competitive bidding.

Estimated Repair Cost:

- Installation and repair of rear blower fan turbine – is \$56,444.39 plus a 10% contingency for a grand total of **\$62,088.83**
-

FINANCIAL IMPACT:

There is no new financial impact. The total Estimated cost of \$62,088.79 for the emergency repairs will be funded through the allocated street sweeper repair line item in the current fiscal year budget.

RECOMMENDATION:

Staff recommends that the City Council discuss and approve Resolution No.2025-547, authorizing the appropriation of \$62,088.83 from the City's allocated street sweeper fund to complete the Elgin Sweeper emergency repair.

ATTACHMENTS:

1. Haaker Repair Estimate

RESOLUTION NO. 2025-94

REPORT, DISCUSS, AND APPROVE RESOLUTION NO. 2025-547 A RESOLUTION OF THE CITY COUNCIL APPROVING AN APPROPRIATION FOR THE EMERGENCY REPAIR OF THE ELGIN STREET SWEEPER AND AUTHORIZING THE USE OF ALLOCATED FUNDS FOR ASSOCIATED COSTS

WHEREAS, the Elgin Air Street Sweeper is an essential piece of equipment used by the City of McFarland Public Works Department to maintain clean streets and ensure public health and safety; and

WHEREAS, in January 2025, the street sweeper began experiencing persistent mechanical issues, including a malfunctioning and unbalanced rear turbine, which has caused severe vibration and led to related electrical failures; and

WHEREAS, while minor interim repairs have been performed, a comprehensive repair is now urgently required to prevent further damage to the equipment and avoid disruption to vital public services; and

WHEREAS, the City has obtained an estimate for the emergency repair of the street sweeper totaling \$62,088.79, including installation and repair of the rear blower fan turbine and associated components; and

WHEREAS, Staff attempted to get multiple quotes for repairs of the Sweeper, but Haaker, the manufacturer of the Sweeper has proprietary parts that only they can source and supply. Per section 2.24.070 sub section E - Purchasing Methods of the Municipal Code, Commodities which can be obtained from only one vendor as determined by the City are exempt from competitive bidding.

WHEREAS, funds have been allocated in the Fiscal Year 2025–26 budget for equipment repairs, including the street sweeper, and staff recommends utilizing those allocated funds for the immediate completion of the repair project.

- **NOW, THEREFORE, BE IT RESOLVED**, by the City Council of the City of McFarland that it hereby finds and determines as follows:
 1. The City Council hereby finds that the repair of the Elgin Street Sweeper is necessary for the continued health, safety, and welfare of the community and constitutes an emergency repair.
 2. The City Council hereby approves the appropriation of \$62,088.79 for the repair of the Elgin Street Sweeper, using funds allocated for equipment repairs in the Fiscal Year

2025–26 budget.

PASSED AND ADOPTED at a regular meeting of the City Council of the City of McFarland on July 9, 2025 by the following vote:

	Aye	Nae	Abstain	Absent
Saul Ayon				
Ricardo Cano				
Anita Gonzalez				
María T. Pérez				
Martin Gutierrez				

CITY OF MCFARLAND

Saul Ayon, Mayor

ATTEST:

Erika De La Cruz, City Clerk

I, _____, City Clerk of the City of McFarland, California, DO HEREBY CERTIFY that the foregoing resolution is a true and accurate copy of the Resolution passed and adopted by the City Council of the City of McFarland on the date and by the vote indicated herein.

APPROVED AS TO FORM:

Nathan Hodges, City Attorney

HAAKER

EQUIPMENT COMPANY

Parts & Service Estimate Form

2070 N. White Ave La Verne CA 91750 Phone: 909-598-2706

Customer: City of McFarland Date: 10/8/2024
Equipment Type: Elgin Crosswind J Serial Number: J40666
Customer Contact: JESSE GUERRA Work Order Number: open upon approval
Customer Email: jguerra@mcfarlandcity.org Estimate Revision: 0
Customer Phone: 661-778-5791
Haaker Contact: Carina Isidro (559) 220-8897

Shipping Method: Ground Shipping To: In Shop

Qty.	Stock No.	Description	Unit Price	Total
1	1133439	FSO-Fan and Upgraded Tensioner (Full Assembly)	\$19,971.77	\$19,971.77
1	1116182	Auxiliary Enclosure	\$18,153.98	\$18,153.98
				\$0.00
				\$0.00

NOTES:

TOTAL PARTS		\$38,125.75
FREIGHT		\$1,600.00
SALES TAX	10.25%	\$3,938.64
HEC LABOR HOURS	60 @ \$ 208.00	\$12,480.00
SUBLET LABOR		
ENV CHARGES/SHOP SUPPLIES	10.0%	\$300.00
TRAVEL		
Grand Total:		\$56,444.39

Approved: By:

Due to fluctuation in materials and components, all estimated prices are subject to change and are not guaranteed.

After tear down additional parts and labor may be required to complete this repair due to unforeseen issues.

Sales tax will be calculated and charged based on current rates for the location of the sale at time of invoice.

Any sales tax shown is subject to change.



City of McFarland

City Council Meeting

STAFF REPORT

Agenda Item No. 9.
Section: CONSENT AGENDA
Meeting Date: July 9, 2025

TO: Honorable Mayor and Council Members

FROM: Diego Viramontes, City Manager
Serrena McCuan, Human Resources Director

SUBJECT: Approval of Resolution No. 2025-91 A RESOLUTION OF THE CITY COUNCIL OF THE CITY OF MCFARLAND APPROVING THE AMENDMENT TO RETENTION INCENTIVE AGREEMENT- CLARIFICATION OF REPAYMENT TERMS AND MODIFICATION OF PAYMENT STRUCTURE

SUMMARY:

The City of McFarland has previously approved the use of retention/hiring incentives for critical public safety positions in order to enhance employee retention and ensure continued service stability. A standard agreement was developed and has been used for recent hires within the McFarland Police Department.

In evaluating the City's recruitment and retention strategy, staff have noted that neighboring agencies have implemented similar incentives. The City of Delano is currently offering a sign-on bonus of \$7,000 for qualifying public safety positions, and the City of Shafter is offering a sign-on incentive totaling \$5,000. These regional practices emphasize the growing need for competitive hiring incentives to attract and retain qualified candidates in a challenging labor market.

Upon recent legal review and feedback, staff recommended modifications to the Retention Incentive Agreement to further clarify: the repayment obligations if any employee voluntarily resigns before completing the full retention period; and the structure of the incentive payment, to be disbursed in two installments.

The following proposed changes are recommended:

1. Payment Structure:

The total \$10,000 Retention incentive will now be split into two payments: \$5,000 to be paid on the initial payment date *after successful completion of the probationary period*, and \$5,000 to be paid on the one-year anniversary of the initial payment date, contingent upon the employee remaining actively employed with the City on that date.

2. Clarified Repayment Terms: Language has been added to clarify that: If the employee voluntarily resigns or is terminated for cause before the second anniversary of the initial payment, they will be required to repay the after-tax value of all incentive payments received. The City reserves the right to offset any amounts owed against final wages or other amounts due at separation. If separation occurs due to disability, death, or termination without cause, no

repayment will be required. These provisions aim to ensure fairness, accountability, and continued alignment with standard City policies, while maintaining McFarland's competitiveness within the region.

FINANCIAL IMPACT:

There is no change in the overall cost of the retention incentive. The structure simply adjusts the timing of payments and strengthens repayment protections for the City.

RECOMMENDATION:

Staff recommends that the City Council approve the revised Retention Incentive Agreement, which includes clarification regarding repayment obligations upon resignation and separate the incentive into two disbursements.

ATTACHMENTS:

1. 07.02.2025.Incentive Payment Agreement (Retention Bonus)

RESOLUTION NO. 2025-91

**A RESOLUTION OF THE CITY COUNCIL OF THE CITY OF MCFARLAND APPROVING
THE AMENDMENT TO RETENTION INCENTIVE AGREEMENT- CLARIFICATION OF
REPAYMENT TERMS AND MODIFICATION OF PAYMENT STRUCTURE**

WHEREAS, the City of McFarland has implemented a Retention Incentive Agreement to improve employee retention, particularly for key public safety personnel; and

WHEREAS, the existing Retention Incentive Agreement provides a one-time lump sum payment of \$10,000 as a hiring and retention incentive for eligible employees; and

WHEREAS, the City wishes to enhance the effectiveness and clarity of the Agreement by modifying the structure of the Incentive to be paid in two equal installments, and by clarifying the terms and conditions under which repayment is required if an employee resigns or is terminated prior to the full retention period; and

WHEREAS, the revised Agreement will require repayment of any portion of the retention incentive received if the employee voluntarily resigns or is terminated for cause before the completion of the two-year retention term, with specific exceptions for termination without cause, disability, or death; and

WHEREAS, the City Council finds that it is in the best interest of the City to approve the updated Retention Incentive Agreement to better align with employee accountability and long-term retention goals.

NOW, THEREFORE, BE IT RESOLVED by the City Council of the City of McFarland as follows:

1. The City Council hereby approves the amended Retention Incentive Agreement substantially in the form presented and authorizes the City Manager or designee to execute said agreement with eligible employees.
2. The updated Agreement shall reflect the following changes:
 - A two-part payment schedule: \$5,000 upon the initial eligibility date and \$5,000 on the one-year anniversary.
 - Clarified language on repayment requirements in the event of early resignation or termination for cause.
3. The City Manager or designee is authorized to take any further actions necessary to implement the provisions of this Resolution.

PASSED AND ADOPTED at a regular meeting of the City Council of the City of McFarland on July 9, 2025 by the following vote:

	Aye	Nae	Abstain	Absent
Saul Ayon				
Ricardo Cano				
Anita Gonzalez				
María T. Pérez				
Martin Gutierrez				

CITY OF MCFARLAND

Saul Ayon, Mayor

ATTEST:

Erika De La Cruz, City Clerk

I, _____, City Clerk of the City of McFarland, California, DO HEREBY CERTIFY that the foregoing resolution is a true and accurate copy of the Resolution passed and adopted by the City Council of the City of McFarland on the date and by the vote indicated herein.

APPROVED AS TO FORM:

Nathan Hodges, City Attorney

CITY OF MCFARLAND
Incentive Payment Agreement

Employee Information

Re: Retention/Hiring Bonus

Dear *Employee*:

This Incentive Payment Agreement (“Agreement”) is made on this [REDACTED] day of [REDACTED], 202[REDACTED], by and between the McFarland Police Department (“MPD”) and the City of McFarland (the “City”) (collectively the “City” or “Employer”) and [REDACTED] (“Employee”). The City and Employee are collectively referred to as the “Parties” where appropriate.

RECITALS

WHEREAS, in light of Employees importance to the continued success of the MPD and to provide Employee you with an incentive to remain with the MPD during the coming years, the City will provide Employee with a Cash Incentive Payment.

WHEREAS, in exchange for the City’s issuance of the Incentive Payment, Employee agrees to reimburse the City either through work (by remaining employed with the City for a specific time period as set forth in this Agreement), or by Repayment (if Employee’s employment is terminated as set forth in this Agreement prior to Employee completing the agreed-upon service to the City).

NOW THEREFORE, in consideration of the mutual covenants and agreements contained herein, and other good and valuable consideration, the receipt and sufficiency of which are hereby acknowledged, the parties agree as follows:

AGREEMENT

- 1. Issuance of Incentive Payment.** The City shall issue payment to Employee in the amount of \$10,000.00 (“Incentive Payment”), less applicable withholdings and deductions as outlined below (the “Payment Date”), subject to the terms and conditions of this Agreement.
 - a. **Payment Structure:** The total \$10,000 Incentive Payment will be split into two payments:
 - i. Payment 1: \$5,000 to be paid within ten (10) days after Employee’s successful completion of the probationary period (“Initial Payment Date”), and
 - ii. Payment 2: \$5,000 to be paid on the one-year anniversary of the Initial Payment Date (“Second Payment Date”), contingent upon the employee remaining actively employed with the City on that date.

2. **Employee Obligation.** Employee agrees to continued employment with the City for a period not less than two years from the Initial Payment Date and the Second Payment Date, subject to the terms and conditions of this Agreement (“Commitment Period”). The Parties agree that Employee’s agreement to continue employment with the City does not confer on Employee any right to continued employment, nor does it change the “At-Will” status of Employee’s employment with the City.
3. **Obligation Satisfied Two (2) Years After the Payment Date.** Employee will have no obligation to pay the City for the Incentive Payment paid pursuant to this Agreement if, on the second annual anniversary of the Incentive Payment, Employee has not voluntarily quit or has not been terminated without “Good Reason” or “For Cause”, as both terms defined in this Agreement below.
4. **Repayment on Early Termination.**
 - a. Termination of Employment by City. If Employees employment with Employer is terminated without “Good Reason” or Employer terminates Employee’s employment “For Cause” before the second anniversary of an Incentive Payment made pursuant to this Agreement, Employee shall immediately pay, without demand, an amount equal to all Incentive Payments made pursuant to this Agreement, with accrued interest at the rate of 10% per year (“Tuition Repayment Obligation”), on a prorated basis based on the remaining time of the Commitment Period. This is a full recourse obligation to Employee, meaning that Employee is personally liable for any repayment obligation under this Agreement
 - i. For purposes of this Agreement, cause shall include, but not be limited to:
 1. Employee’s willful and continued failure to perform substantially Employee’s duties with Employer;
 2. Theft, or attempted theft, financial mismanagement, material dishonesty, willful or persistent breach of duties, engaging in conduct tending to bring embarrassment or disrepute to Employer, unauthorized or excessive absences.
 3. A formal investigation commissioned by Employer and conducted by a third-party investigator hired by Employer in which Employer has determined that you have engaged in unlawful discrimination or harassment of Employees or any third party while on City Premises or on City time.
 4. Conviction of any felony, or for any misdemeanor involving moral turpitude, corruption or dishonesty. “Conviction” shall

include any guilty plea, plea of nolo contendere, or any other disposition other than a dismissal of charges or acquittal.

5. Employee's willful engagement in illegal conduct or gross misconduct.

ii. For purposes of this Agreement, good reason means:

1. Employer fails to maintain fiscal strength enough to retain Employee's employment.
2. Employer unlawfully discriminates against Employee.

b. Termination of Employment by Employee

- i. In the event Employee voluntarily quits his/her employment with the City less than two (2) years after an Incentive Payment is made pursuant to this Agreement, Employee shall immediately pay, without demand, an amount equal to all Incentive Payments made pursuant to this Agreement, with accrued interest at the rate of 10% per year ("Tuition Repayment Obligation"), on a prorated basis based on the remaining time of the Commitment Period. This is a full recourse obligation to Employee, meaning that Employee is personally liable for any repayment obligation under this Agreement.

Employee's employment remains pursuant to the terms of the Memorandum of Understanding between the City and the McFarland Police Officers Association and nothing in this agreement shall be interpreted to be in conflict with or to eliminate or modify in any way your At-Will employment status under the Memorandum of Understanding.

- 5. No Repayment Upon Certain Terminations.** For the avoidance of doubt, Employee will not be required to repay the Incentive Payment if (i) Employee's employment terminates after more than two years since an Incentive Payment was made pursuant to this Agreement for any reason, (ii), in the event of Employee's death or termination due to your disability, or (iii) Employee's employment is terminated by Employer without Cause or by Employee for Good Reason; provided that, in each case, except upon termination due to death, Employee executes and does not revoke a release of claims in a form reasonably satisfactory to Employer within 30 days after such termination.
- 6. No Right to Continued Employment.** Nothing in this Agreement will confer upon Employee any right to continued employment with Employer or interfere in any way with the right of Employer to terminate Employee's employment at any time and in conformance with the Current Memorandum of Understanding between Employer and the McFarland Police Officer's Association.

7. **Settlement of Claims.** In the event that Employee is required to repay the Incentive Payment pursuant to Section 4, Employee agrees that Employer may offset any amounts owed by Employer to Employee against the amount that Employee are required to repay.
8. **Benefits Bearing.** The Incentive Payment will be taken into account as a regular annual bonus for purposes of computing the amount of compensation used to determine any retirement or other benefit under Employer benefit plan or arrangement.
9. **No Assignments; Successors.** This Agreement is personal to Employee and Employee may not assign or delegate any right or obligation under it. This Agreement will inure to the benefit of any successor to the City.
10. **Entire Agreement.** This Agreement constitutes the complete understanding between the Parties, is fully integrated, and supersedes any and all prior agreements – including any promises, representations, or inducements, no matter their form, concerning the subject matter of this Agreement. No subsequent agreements, promises, representations, or inducements will be binding unless recorded in a written document, which specifically references this Agreement and is signed by the Parties or their authorized representatives. The Parties acknowledge that this Agreement may be used as evidence in any subsequent proceeding in which either Party alleges a breach of this Agreement or seeks to enforce its terms, provisions, obligations, or as compelled by law.
11. **Captions.** The headings used in this Agreement are inserted for reference purposes only and shall not be deemed to limit or affect in any way the meaning or interpretation of any of the terms or provisions of this Agreement.
12. **Severability.** If any provision contained in this Agreement is held invalid or unenforceable by a court of competent jurisdiction, the remainder of this Agreement shall be deemed severable and shall not be affected thereby and same shall remain in full force and effect.
13. **Amendment.** This Agreement may only be amended by a writing executed by all parties.
14. **Governing Law and Venue.** This Agreement shall be governed by and construed in accordance with the laws of the State of California. Any action or motion to enforce the terms or conditions of this Agreement shall be brought only in the Superior Court of California for the County of Kern.
15. **Waiver.** Waiver by any party of any breach of this Agreement by the other party, whether such waiver be direct or implied, shall not be construed as a continuing waiver or consent to any subsequent breach of this Agreement on the part of the other party.

16. Attorneys' Fees. If either party commences any action or proceeding relating to this Agreement or the enforcement of any provision of this Agreement against the other party, the prevailing party, in such action or proceeding, shall be entitled to recover reasonable attorneys' fees, costs, and all other litigation costs.

17. Counterparts. This Agreement may be executed in counterparts and the respective signature pages for each party may thereafter be attached to the body of this Agreement to constitute one integrated Agreement which is as fully effective and binding as if the entire document had been signed at one time.

18. Independent Legal Advice. Employer and Employee represent and warrant to each other that each has received legal advice from independent and separate legal counsel with respect to the legal effect of this Agreement or had the opportunity to do so and Employer and Employee further represent and warrant that each has carefully reviewed this entire Agreement and that each term thereof is understood and that the terms of this Agreement are contractual and not a mere recital. This Agreement shall not be construed against the Party or its representatives who drafted it or who drafted any portion thereof.

If you **agree** to the terms of this Incentive Payment Agreement and wish to receive the Incentive Payment as outlined, please sign and date below.

If you **do not wish to accept** the terms of this Agreement or wish to decline the Incentive Payment, please indicate that by checking the box and signing below.

I decline the Incentive Payment and/or do not accept the terms of this Agreement.

Dated: _____

Signature: _____

Name: _____



City of McFarland

City Council Meeting

STAFF REPORT

Agenda Item No. 10.
Section: PUBLIC HEARINGS
Meeting Date: July 9, 2025

TO: Honorable Mayor and Council Members

FROM: Diego Viramontes, City Manager
Paul Saldaña , Economic Development Manager
Erika De La Cruz, City Clerk

SUBJECT: Approval of Resolution No. 2025-90 A RESOLUTION OF THE CITY COUNCIL OF THE CITY OF MCFARLAND CALLING FOR THE HOLDING OF A SPECIAL MUNICIPAL ELECTION TO BE HELD ON TUESDAY NOVEMBER 4, 2025 FOR THE SUBMISSION OF A BALLOT MEASURE TO ADOPT AN ORDINANCE APPROVING TRANSACTIONS AND USE GENERAL TAX TO BE ADMINISTERED BY THE CALIFORNIA DEPARTMENT OF TAX AND FEE ADMINISTRATION

SUMMARY:

Mayor Saul Ayon has requested the Council consider calling a Special Election on November 4, 2025 for consideration of Ballot Measure to Adopt an Ordinance Approving a One Cent (1.00%) Retail Transactions and Use General Tax to Provide Funding for Essential City Services and Projects in the City of McFarland such as Police Patrols, Quick 9-1-1 Response, Repairing Potholes and Infrastructure, Maintaining Streets, Revitalizing Downtown, Improving Community Facilities, Parks, Senior Services, and other General City Services.

Ordinance

Under the State Revenue and Taxation Code, if the Council wishes to increase the City's sales tax, the City Council must propose an ordinance to City voters establishing the sales tax by a 2/3 vote of the Council. The proposed ordinance is attached to the Council resolution calling for the election. Thereafter, the voters would vote on the ordinance via the ballot measure. Approval requires a 50% plus one vote of the votes cast. The ordinance is intended as a general sales tax, includes accountability language (annual audit, report, and a Citizens Oversight Committee), and includes text required by the California Department of Tax and Fee Administration.

If the local revenue sales tax measure passes and the ordinance is adopted, the City of McFarland will enter into two contracts with the State: (1) to set up the tax and (2) for ongoing administration. The tax will not be operative until the first day of the first calendar quarter commencing more than 110 days after the adoption of this ordinance at the election. This means that a tax passed in November 2025 would not be imposed and collected until February 2026. The ordinance would also become part of the McFarland Municipal Code.

Ballot Measure Resolution

The Elections Code has specific requirements for placing a ballot measure on the ballot. The

attached resolution includes text required by the Elections Code as to the placement on the ballot, consolidation of Election, arguments, the ballot question, synopsis of the measure, and requirements of the Elections Office, City Clerk, and City Attorney.

The attached resolution proposes to call a special election and place the measure on the November ballot an ordinance that would implement a local transaction and use tax in the amount of one cent (1.00%). This will be a general tax. Passage requires a 50% plus one vote of the votes cast, and the City Council must determine by a two-thirds vote to place it on the ballot. Voters will be voting on adoption of the entire Ordinance, but the ballot question to be placed before the voters is limited by statute to 75 words or less, and reads as follows:

MEASURE __

To provide funding for essential city services and projects in the City of McFarland such as: police patrols, crime prevention, and quick 9-1-1 emergency response; repairing potholes and infrastructure, maintaining streets, revitalizing the downtown area, and improving community facilities, parks, senior services, and other general city services, shall the measure establishing a one percent sales tax providing approximately \$1,000,000 annually until ended by voters, requiring citizen oversight, independent audits, and all funds controlled locally, be adopted?

The entire Ordinance will be accessible to the public via the County Elections Office, the City's website, and the McFarland City Clerk's Office.

Council Preparation of Argument in Support of Measure

Under Elections Code section 9282, a ballot argument on this City Council-sponsored measure may be authored by the City Council, or any members of the Council authorized by that body, or any individual voter who is eligible to vote on the measure, or bona fide association of citizens, or any combination of voters and associations. The City Council is designating the Mayor and Vice Mayor to author the ballot argument in support of the measure. The two names are included in the resolution. The argument may not exceed three hundred (300) words. Those two members may solicit up to three additional signatories.

Impartial Analysis

As required by the Elections Code, the City Attorney will prepare an impartial analysis of the measure, not to exceed five hundred (500) words in length, showing the effect of the measure on the existing law and the operation of the measure, and transmit the impartial analysis to the Elections Division by the deadline set by the Elections Office.

Roles and Limitations During Ballot Measure Campaign Period

The City can provide educational materials to the public, informing them about the Measure. But the City cannot expend any time, money, staff resources, or effort advocating a position supporting passage of the ballot measure. Councilmembers and staff can work on the campaign on their own time and at their own expense, provided it is made clear that they are doing so on their own time and not with City resources. The City Attorney will provide further guidance on this if the Resolution is adopted.

FINANCIAL IMPACT:

Special election costs estiamte at \$38,000

Potential new revenue to City \$1,000,000 annually.

RECOMMENDATION:

Adopt Resolution No. 2025-90 calling a special election to be held November 4, 2025 for consideration of a ballot measure to adopt an ordinance approving transactions and use general tax to be administered by the California Department of Tax and Fee Administration.

ATTACHMENTS:

1. Attachment A - Resolution 2025-90 Proposed Ordinance Adding Sales Tax

RESOLUTION NO. 2025-90

A RESOLUTION OF THE CITY COUNCIL OF THE CITY OF MCFARLAND CALLING FOR THE HOLDING OF A SPECIAL MUNICIPAL ELECTION TO BE HELD ON TUESDAY NOVEMBER 4, 2025 FOR THE SUBMISSION OF A BALLOT MEASURE TO ADOPT AN ORDINANCE APPROVING TRANSACTIONS AND USE GENERAL TAX TO BE ADMINISTERED BY THE CALIFORNIA DEPARTMENT OF TAX AND FEE ADMINISTRATION

WHEREAS, under the provisions of the laws relating to general law cities in the State of California a Special Municipal Election shall be held in the City of McFarland on November 4, 2025, to submit to the voters at the election a question relating to transaction and use general tax; and

WHEREAS, the City Council desires to submit to the voters at the election a question relating to imposing a one percent (1.00%) Local Sales Tax; and

WHEREAS, the City of McFarland provides essential public safety and park services to the residents of McFarland; and

WHEREAS, a vibrant and healthy downtown promotes economic well-being and growth for the City and encourages new business development in the City; and

WHEREAS, the City General Fund lacks funds for basic repairs and maintenance to streets, storm drains and facilities, construction of senior center and police station, and other similar projects, as well as downtown revitalization; and

WHEREAS, keeping the City clean, safe and well-maintained attracts families to the community and maintains our quality of life and local property values; and

WHEREAS, the City Council has reviewed its economic forecast and determined that without an additional revenue source, the City will be unable to maintain high-quality essential city services, repair potholes and maintain local streets and ensure the City has enough police officers to respond quickly to 9-1-1 emergencies; and

WHEREAS, such a measure will also allow the City to provide police services including

neighborhood police patrols, crime prevention and investigations and expand and improve the number of services provided locally to seniors; and

WHEREAS, the State cannot take away funds from a local sales tax measure and a measure will have a clear system of fiscal accountability with an independent citizens’ oversight committee and annual audits to ensure funds are spent properly and all funds stay local; and

WHEREAS, at its meeting of July 9, 2025 the Council considered a staff report, public testimony, and deliberated on the matter regarding submitting a ballot measure to the voters concerning a General Sales Tax; and

WHEREAS, Revenue and Taxation Code section 7285.9 authorizes the City Council to levy a transactions and use tax for general purposes, if the ordinance proposing the tax is approved by a two thirds vote of all members of the City Council and the tax is approved by a majority vote of the qualified voters of the city voting in an election on the issue; and

WHEREAS, the City Council wishes to approve the attached transactions and use tax ordinance and submit it to the votes in the form of the McFarland Essential City Services and Public Safety Measure which imposes a one percent (1.00%) transactions and use tax to be administered by the California Department of Tax and Fee Administration, subject to adoption by the voters of the City; and

WHEREAS, the California Department of Tax and Fee Administration shall collect the tax from retailers subject to the tax and remit the funds to the City.

NOW, THEREFORE, BE IT RESOLVED, by the City Council of the City of McFarland that it hereby finds and determines as follows:

SECTION 1. That pursuant to the requirements of the laws of the State of California relating to General Law Cities, there is called and ordered to be held in the City of McFarland, California on Tuesday, November 4, 2025 a Special Municipal Election.

SECTION 2. The question to be submitted to the voters with respect to the ballot measure shall be printed on the election ballot with the title and in the form set forth as follows:

MEASURE __	
To provide funding for essential city services and projects in the City of McFarland such as: police patrols, crime prevention, and quick 9-1-1 emergency response; fire service; repairing roads, potholes and infrastructure, maintaining streets, revitalizing the downtown area, and improving community facilities, parks, senior services, and other general city services, shall the measure adopt a	YES NO

one percent sales tax providing approximately \$1,000,000 annually until ended by voters, requiring citizen oversight, independent audits, and all funds controlled locally, be adopted?

SECTION 3. The following constitutes the synopsis of the measure to be voted

on for purposes of meeting the publication requirements of Elections Code Section 12111:

MEASURE TO BE VOTED ON

Notice is hereby given that the following measure is to be voted on at the general municipal election to be held in the City of McFarland, on Tuesday, the 4th day of November, 2025. **ADOPTION OF ORDINANCE APPROVING A ONE PERCENT (1.00%) TRANSACTIONS AND USE TAX. Ordinance No. ##-2025** would amend Chapter 3.22 of the McFarland Municipal Code establishing a one percent sales tax and generate approximately \$1,000,000 annually. To become effective, Ordinance No. ##-2025 as a general tax measure must be approved by a majority of the City’s voters at the November 4, 2025, special municipal election. If approved by the voters, the ordinance would continue until ended by the voters. The ordinance would allow the City to provide funding for essential city services and projects such as: police patrols, crime prevention, and quick 9-1-1 emergency response; fire service; repairing roads, potholes, maintaining streets, repairing infrastructure, revitalizing the downtown area, and improving community facilities, parks, senior services, and other general city services, shall the measure establishing a one cent sales tax providing approximately \$1,000,000 annually until ended by voters. The ordinance requires citizen oversight and annual independent audits.

Dated: _____

City of McFarland, City Elections Official

SECTION 4. The full text of the ordinance submitted to the voters is attached as Exhibit ‘A’ and incorporated by reference. The full text of the proposed ordinance is not required to be printed in the Sample Ballot and Voters Pamphlet. However, the full text of the measure shall be made available to the public and to any voter at the Office of the Kern County Clerk/Registrar of Voters and the McFarland City Clerk’s Office.

SECTION 5. Passage of this measure requires a majority (50% plus 1) of votes cast at the election.

SECTION 6. The City of McFarland requests that the Kern County Clerk/Registrar of Voters conduct the election and canvass the returns, and the City consents to reimburse the Registrar of Voters for all costs incurred by said services.

SECTION 7. In all particulars not recited in this resolution, the election shall be held and conducted as provided by law for holding municipal elections.

SECTION 8. Arguments in favor or against the proposed measure are permissible and shall be filed with the Kern County Clerk/Registrar in accordance with Elections Code Section 9282. Saul Ayon and Ricardo Cano are authorized to prepare and file a written argument in favor of the proposed measure not to exceed 300 words on behalf of the City Council. The City Manager and City Clerk are authorized to provide input to the Kern County Clerk/Registrar in determining a letter designation for this measure. In the event that an argument is filed against the Measure, Saul Ayon and Ricardo Cano are also authorized to submit a rebuttal argument on behalf of the City Council.

SECTION 9. The Kern County Clerk/Registrar of Voters shall give the appropriate notices for the election and shall conduct the election pursuant to appropriate provisions of state law. The City of McFarland acknowledges the Kern County Clerk/Registrar may conduct the election in accordance with Elections Code 10418.

SECTION 10. The City Attorney shall prepare an impartial analysis of the measure in accordance with Elections Code Section 9280 and file it with the Kern County Clerk/Registrar of Voters.

SECTION 11. The City Clerk shall file a certified copy of this resolution with the Kern County Clerk/Registrar of Voters as required by applicable law. The City Clerk is hereby authorized and directed to work with the Kern County Clerk/Registrar of Voters and take all steps necessary to cause placement of the Measure on the ballot.

SECTION 12. The City Clerk and City Attorney are authorized to make any typographical, clerical, non-substantive corrections to this resolution as may be deemed necessary by the Kern County Clerk/Registrar of Voters.

SECTION 13. This Resolution is not subject to the California Environmental Quality Act (“CEQA”) pursuant to Section 15060(c)(2) of the CEQA guidelines (Title 14, Chapter 3 of the California Code of Regulations) because the activity will not result in a direct or reasonably foreseeable indirect physical change in the environment, and Section 15060(c)(3) because the activity is not a project as defined in Section 15378 of the CEQA Guidelines because it has no potential for resulting in physical change to the environment, directly or indirectly

PASSED AND ADOPTED at a regular meeting of the City Council of the City of McFarland on July 9, 2025 by the following vote:

	Aye	Nae	Abstain	Absent
Saul Ayon				
Ricardo Cano				
Anita Gonzalez				
María T. Pérez				
Martin Gutierrez				

CITY OF MCFARLAND

Saul Ayon, Mayor

ATTEST:

Erika De La Cruz, City Clerk

I, _____, City Clerk of the City of McFarland, California, DO HEREBY CERTIFY that the foregoing resolution is a true and accurate copy of the Resolution passed and adopted by the City Council of the City of McFarland on the date and by the vote indicated herein.

APPROVED AS TO FORM:

Nathan Hodges, City Attorney

ORDINANCE NO. ###-2025

AN ORDINANCE OF THE CITY OF MCFARLAND AMENDING CHAPTER 3.22 TO THE MCFARLAND MUNICIPAL CODE IMPOSING A GENERAL ONE PERCENT (1.00%) TRANSACTIONS AND USE TAX TO BE ADMINISTERED BY THE CALIFORNIA DEPARTMENT OF TAX AND FEE ADMINISTRATION

THE PEOPLE OF THE CITY OF MCFARLAND DO ORDAIN AS FOLLOWS:

SECTION 1. Chapter 3.22 of the McFarland Municipal Code entitled TRANSACTIONS AND USE TAX (VOTER APPROVED) is amended as stated below. Deletions are indicated by ~~strikethroughs~~, and additions are indicated by underlines.

CHAPTER 3.22

TRANSACTIONS AND USE TAX (VOTER APPROVED)

Sections:

- 3.22.010 Title.
- 3.22.020 Operative Date.
- 3.22.030 Purpose.
- 3.22.040 Use and Expenditure of Tax Revenue.
- 3.22.050 Annual Audit and Citizen Oversight.
- 3.22.060 Contract with State.
- 3.22.070 Transactions Tax Rate.
- 3.22.080 Place of Sale.
- 3.22.090 Use Tax Rate.
- 3.22.100 Adoption of Provisions of State Law.
- 3.22.110 Limitations on Adoption of State Law and Collection of Use Taxes.
- 3.22.120 Permit Not Required.
- 3.22.130 Exemptions and Exclusions.
- 3.22.140 Amendments.
- 3.22.150 Enjoining Collection Forbidden.
- 3.22.160 Severability.
- 3.22.170 Termination.

3.22.010. Title.

This ordinance shall be known as the Transactions and Use Tax Ordinance for the City of McFarland and is referred to herein as “Sales Tax Ordinance”. The City of McFarland hereinafter shall be called “City.” This ordinance shall be applicable in the incorporated territory of the City.

3.22.020. Operative Date.

“Operative Date” means the first day of the first calendar quarter commencing more than 110 days after the adoption of this ordinance, the date of such adoption being as set forth below.

3.22.030. Purpose.

This ordinance is adopted to achieve the following, among other purposes, and directs that the provisions hereof be interpreted to accomplish those purposes:

- A. To impose a retail transaction and use tax in accordance with the provisions of Part 1.6 (commencing with Section 7251) of Division 2 of the Revenue and Taxation Code and Section 7285.91 of Part 1.7 of Division 2 which authorizes the City to adopt this tax ordinance which shall be operative if two-thirds of the electors voting on the measure vote to approve the imposition of the tax at an election called for that purpose.
- B. To adopt a retail transaction and use tax ordinance that incorporates provisions identical to those of the Sales and Use Tax Law of the State of California insofar as those provisions are not inconsistent with the requirements and limitations contained in Part 1.6 of Division 2 of the Revenue and Taxation Code.
- C. To adopt a retail transaction and use tax ordinance that imposes a tax and provides a measure therefore that can be administered and collected by the State Board of Equalization in a manner that adapts itself as fully as practicable to, and requires the least possible deviation from, the existing statutory and administrative procedures followed by the State Board of Equalization in administering and collecting the California State Sales and Use Taxes.
- D. To adopt a retail transaction and use tax ordinance that can be administered in a manner that will be, to the greatest degree possible, consistent with the provisions of Part 1.6 of Division 2 of the Revenue and Taxation Code, minimize the cost of collecting the transactions and use taxes, and at the same time, minimize the burden of record keeping upon persons subject to taxation under the provisions of this ordinance.

3.22.040 Use and Expenditure of Tax Revenue.

While the sales tax under this Chapter is a general tax, the proceeds of the tax imposed by this Chapter shall still be placed in a designated fund. The Director of Finance shall establish and keep such accounts as may be necessary to account for said taxes.

3.22.050 Annual Audit, Report, and Citizen Oversight.

- A. The revenues from the tax imposed by this Chapter shall be subject to the annual audit performed by the City’s independent auditor of the City’s books, records, accounts, and fiscal procedures and which is reported in the City’s Comprehensive Annual Financial Report.

- B. In addition to the annual audit, an Annual Review Report shall be prepared by the City setting forth the amount of revenues received from the tax imposed by this Chapter, amount of disbursements, and description of expenditures. The purpose is to assure accountability and the proper disbursement of the proceeds of the taxes collected under this ordinance. The Annual Review Report shall be filed in the City Clerk's Office not later than January 1 of each fiscal year in which the tax is collected.

- C. A Sales Tax Oversight Committee comprised of City residents shall be established by the City Council to review the Annual Review Report and related records and to make comments and recommendations to the City Council to ensure compliance with this ordinance.

3.22.060 Contract With State.

Prior to the operative date, the City shall contract with the California Department of Tax and Fee Administration to perform all functions incident to the administration and operation of this transactions and use tax ordinance; provided, that if the City shall not have contracted with the California Department of Tax and Fee Administration prior to the operative date, it shall nevertheless so contract and in such a case the operative date shall be the first day of the first calendar quarter following the execution of such a contract.

3.22.070 Transactions Tax Rate.

For the privilege of selling tangible personal property at retail, a tax is hereby imposed upon all retailers in the incorporated territory of the City at the rate of ~~one percent (1.00%)~~ two percent (2.00%) of the gross receipts of any retailer from the sale of all tangible personal property sold at retail in said territory on and after the operative date of this ordinance.

3.22.080 Place of Sale.

For the purposes of this ordinance, all retail sales are consummated at the place of business of the retailer unless the tangible personal property sold is delivered by the retailer or his agent to an out-of-state destination or to a common carrier for delivery to an out-of-state destination. The gross receipts from such sales shall include delivery charges, when such charges are subject to the state sales and use tax, regardless of the place to which delivery is made. In the event a retailer has no permanent place of business in the State or has more than one place of business, the place or places at which the retail sales are consummated shall be determined under rules and regulations to be prescribed and adopted by the California Department of Tax and Fee Administration.

3.22.090 Use Tax Rate.

An excise tax is hereby imposed on the storage, use or other consumption in the City of tangible personal property purchased from any retailer on and after the operative date of this ordinance for storage, use or other consumption in said territory at the rate of one percent (1.00%) of the sales price of the property. The sales price shall include delivery charges when such charges are subject to state sales or use tax regardless of the place to which delivery is made.

3.22.100 Adoption of Provisions of State Law.

Except as otherwise provided in this ordinance and except insofar as they are inconsistent with the provisions of Part 1.6 of Division 2 of the Revenue and Taxation Code, all of the provisions of Part 1 (commencing with Section 6001) of Division 2 of the Revenue and Taxation Code are hereby adopted and made a part of this ordinance as though fully set forth herein.

3.22.110 Limitations on Adoption of State Law and Collection of Use Taxes.

In adopting the provisions of Part 1 of Division 2 of the Revenue and Taxation Code:

- A. Wherever the State of California is named or referred to as the taxing agency, the name of this City shall be substituted therefor. However, the substitution shall not be made when:
 1. The word "State" is used as a part of the title of the State Controller, State Treasurer, Victim Compensation and Government Claims Board, State Board of Equalization, State Treasury, or the Constitution of the State of California;
 2. The result of that substitution would require action to be taken by or against this City or any agency, officer, or employee thereof rather than by or against the State Board of Equalization, in performing the functions incident to the administration or operation of this Ordinance.
 3. In those sections, including, but not necessarily limited to sections referring to the exterior boundaries of the State of California, where the result of the substitution would be to:
 - a. Provide an exemption from this tax with respect to certain sales, storage, use or other consumption of tangible personal property which would not otherwise be exempt from this tax while such sales, storage, use or other consumption remain subject to tax by the State under the provisions of Part 1 of Division 2 of the Revenue and Taxation Code; or
 - b. Impose this tax with respect to certain sales, storage, use or other consumption of tangible personal property which would not be subject to tax by the state under the said provision of that code.
 4. In Sections 6701, 6702 (except in the last sentence thereof), 6711, 6715, 6737, 6797 or 6828 of the Revenue and Taxation Code. 49 City Council Staff Report
Page 11 of 13 Tax Initiative

- B. The word “City” shall be substituted for the word “State” in the phrase “retailer engaged in business in this State” in Section 6203 and in the definition of that phrase in Section 6203.

3.22.120 Permit Not Required.

If a seller's permit has been issued to a retailer under Section 6067 of the Revenue and Taxation Code, an additional transactor's permit shall not be required by this ordinance.

3.22.130 Exemptions and Exclusions.

- A. There shall be excluded from the measure of the transactions tax and the use tax the amount of any sales tax or use tax imposed by the State of California or by any city, city and county, or county pursuant to the Bradley-Burns Uniform Local Sales and Use Tax Law or the amount of any state-administered transactions or use tax.
- B. There are exempted from the computation of the amount of transactions tax the gross receipts from:
 - 1. Sales of tangible personal property, other than fuel or petroleum products, to operators of aircraft to be used or consumed principally outside the county in which the sale is made and directly and exclusively in the use of such aircraft as common carriers of persons or property under the authority of the laws of this State, the United States, or any foreign government.
 - 2. Sales of property to be used outside the City which is shipped to a point outside the City, pursuant to the contract of sale, by delivery to such point by the retailer or his agent, or by delivery by the retailer to a carrier for shipment to a consignee at such point. For the purposes of this paragraph, delivery to a point outside the City shall be satisfied:
 - a. With respect to vehicles (other than commercial vehicles) subject to registration pursuant to Chapter 1 (commencing with Section 4000) of Division 3 of the Vehicle Code, aircraft licensed in compliance with Section 21411 of the Public Utilities Code, and undocumented vessels registered under Division 3.5 (commencing with Section 9840) of the Vehicle Code by registration to an out-of-City address and by a declaration under penalty of perjury, signed by the buyer, stating that such address is, in fact, his or her principal place of residence; and
 - b. With respect to commercial vehicles, by registration to a place of business out-of-City and declaration under penalty of perjury, signed by the buyer, that the vehicle will be operated from that address.

3. The sale of tangible personal property if the seller is obligated to furnish the property for a fixed price pursuant to a contract entered into prior to the operative date of this ordinance.
 4. A lease of tangible personal property which is a continuing sale of such property, for any period of time for which the lessor is obligated to lease the property for an amount fixed by the lease prior to the operative date of this ordinance.
 5. For the purposes of subparagraphs (3) and (4) of this section, the sale or lease of tangible personal property shall be deemed not to be obligated pursuant to a contract or lease for any period of time for which any party to the contract or lease has the unconditional right to terminate the contract or lease upon notice, whether or not such right is exercised.
- C. There are exempted from the use tax imposed by this ordinance, the storage, use or other consumption in this City of tangible personal property:
1. The gross receipts from the sale of which have been subject to a transactions tax under any state administered transactions and use tax ordinance.
 2. Other than fuel or petroleum products purchased by operators of aircraft and used or consumed by such operators directly and exclusively in the use of such aircraft as common carriers of persons or property for hire or compensation under a certificate of public convenience and necessity issued pursuant to the laws of this State, the United States, or any foreign government. This exemption is in addition to the exemptions provided in Sections 6366 and 6366.1 of the Revenue and Taxation Code of the State of California.
 3. If the purchaser is obligated to purchase the property for a fixed price pursuant to a contract entered into prior to the operative date of this ordinance.
 4. If the possession of, or the exercise of any right or power over, the tangible personal property arises under a lease which is a continuing purchase of such property for any period of time for which the lessee is obligated to lease the property for an amount fixed by a lease prior to the operative date of this ordinance.
 5. For the purposes of subparagraphs (3) and (4) of this section, storage, use, or other consumption, or possession of, or exercise of any right or power over, tangible personal property shall be deemed not to be obligated pursuant to a contract or lease for any period of time for which any party to the contract or lease has the unconditional right to terminate the contract or lease upon notice, whether or not such right is exercised.

6. Except as provided in subparagraph (7), a retailer engaged in business in the City shall not be required to collect use tax from the purchaser of tangible personal property, unless the retailer ships or delivers the property into the City or participates within the City in making the sale of the property, including, but not limited to, soliciting or receiving the order, either directly or indirectly, at a place of business of the retailer in the City or through any representative, agent, canvasser, solicitor, subsidiary, or person in the City under the authority of the retailer.
 7. “A retailer engaged in business in the City” shall also include any retailer of any of the following: vehicles subject to registration pursuant to Chapter 1 (commencing with Section 4000) of Division 3 of the Vehicle Code, aircraft licensed in compliance with Section 21411 of the Public Utilities Code, or undocumented vessels registered under Division 3.5 (commencing with Section 9840) of the Vehicle Code. That retailer shall be required to collect use tax from any purchaser who registers or licenses the vehicle, vessel, or aircraft at an address in the City.
- D. Any person subject to use tax under this ordinance may credit against that tax any transactions tax or reimbursement for transactions tax paid to a district imposing, or retailer liable for a transactions tax pursuant to Part 1.6 of Division 2 of the Revenue and Taxation Code with respect to the sale to the person of the property the storage, use or other consumption of which is subject to the use tax.

3.22.140 Amendments.

- A. All amendments subsequent to the effective date of this ordinance to Part 1 of Division 2 of the Revenue and Taxation Code relating to sales and use taxes and which are not inconsistent with Part 1.6 and Part 1.7 of Division 2 of the Revenue and Taxation Code, and all amendments to Part 1.6 and Part 1.7 of Division 2 of the Revenue and Taxation Code, shall automatically become a part of this ordinance, provided however, that no such amendment shall operate so as to affect the rate of tax imposed by this ordinance. The foregoing amendments shall not require voter approval.
- B. The following amendments to this ordinance must be approved by the voters of the City:
 1. Increasing the tax rate or revising the methodology for calculating the tax such that a tax increase would result or
 2. Imposing the tax on transactions and uses not previously subject to the tax (unless such amendment occurs automatically by operation of preceding paragraph A).

3.22.150 Enjoining Collection Forbidden.

No injunction or writ of mandate or other legal or equitable process shall issue in any suit, action or proceeding in any court against the State or the City, or against any officer of the State or the City, to prevent or enjoin the collection under this ordinance, or Part 1.6 of Division 2 of the Revenue and Taxation Code, of any tax or any amount of tax required to be collected.

3.22.160 Severability.

If any provision of this ordinance or the application thereof to any person or circumstance is held invalid, the remainder of the ordinance and the application of such provision to other persons or circumstances shall not be affected thereby.

3.22.170 Termination Date.

The authority to levy the tax imposed by this Ordinance shall expire when terminated by the voters of the City of.

SECTION 2. Majority Voter Approval. The tax imposed by this ordinance is a general tax. This tax shall be effective only if approved by a majority (50% plus 1) of the City’s voters voting thereon at the November 4, 2025 special City election.

SECTION 3. Effective Date. This ordinance relates to the levying and collecting of the City transactions and use taxes and shall take effect immediately.

SECTION 4. Certification and Publication. The City Clerk shall certify the final approval of this Ordinance, publish the same as required by law, and forward a copy of the adopted Ordinance to the California Department of Tax and Fee Administration.

The foregoing ordinance was passed and approved for placement on the ballot by a 2/3 vote of the City Council at a noticed public hearing of the City Council held on July 9, 2025, by the following vote:

AYES: _____

NOES: _____

ABSENT: _____

ABSTAIN: _____

I HEREBY CERTIFY that the foregoing Ordinance was adopted by the voters of the City of McFarland at the regular election held on _____, by the following vote:

YES: _____

NO: _____

ATTEST

Erika De La Cruz, City Clerk

CITY OF MCFARLAND

By: _____
Saul Ayon, Mayor

APPROVED AS TO FORM:

By: _____
Nathan M. Hodges, City Attorney
Hodges Law Group



City of McFarland

City Council Meeting

STAFF REPORT

Agenda Item No. 11.
Section: PUBLIC HEARINGS
Meeting Date: July 9, 2025

TO: Honorable Mayor and Council Members

FROM: Diego Viramontes, City Manager
Megan Snyder, Community Development Director
Brianahi De Leon, Senior City Planner

SUBJECT: Approval of Resolution No. 2025-82 TO APPROVE THE CANCELLATION OF LAND USE RESTRICTIONS, LAND CONSERVATION ACT, AGRICULTURE PRESERVE NO. 7 AND AMENDING LAND USE CONTRACT

SUMMARY:

The applicant, Five Haven, and owner of APN: 060-070-02 is requesting the cancellation of a 38.18-acre parcel that is subject to the Williamson Act Land Use Contract, which was recorded on February 28, 1969, in book 4250 page 723 of the Official Records. The applicant submitted a non-renewal (Attachment 2) back in December 2023 that was processed by staff and recorded. Following the recording, the applicant submitted a Lot Line Adjustment request for the same 38.18 ac parcel. The Lot Line Adjustment has already been approved and recorded. The parcel was annexed in 2022 through Annexation 18 and was pre-zoned R-1 and R-2. The applicant also submitted a Tentative Parcel Map (TPM 12606) which will be processed and presented at our future meeting. In order to complete the Tentative Parcel Map, it is required that the applicant complete a Petition for Cancellation of Land Conservation. California Government Code Section 51282(a) states your Board may grant tentative approval of cancellation of a contract only if one of the following findings is made:

- (1) That the cancellation is consistent with the purposes of Chapter 7;
- (2) That the cancellation is in the public interest.

For the purpose of clarification, Chapter 7 of the Government Code is the California Land Conservation Act of 1965 and is referred to as the Williamson Act. The California Land Conservation Act was enacted to guarantee the future agricultural use of what is considered to be the State's best agricultural land and contains certain provisions of eligibility. In exchange for enrolling property into the Williamson Act, landowners are entitled to a reduction in taxes in order to guarantee the continued use of the land for agricultural purposes. The applicants assert that approval of the cancellation request is consistent with the purposes of Chapter 7 and, therefore, is in accordance with California Government Code Section 51282(a)(1).

In order for the council to approve the cancellation under the referenced provision, the following findings must be made pursuant to California Government Code Section 51282(b):

- (1) The cancellation is for land on which a notice of non-renewal has been served pursuant to Section 51245;
 - a. The Notice of non-renewal was made and recorded on December 15, 2025.

- (2) The cancellation is not likely to result in the removal of adjacent lands from agricultural use;
 - a. Surrounding properties, including those adjacent, are not what resulted in the cancellation request. The property was a vacant and abandoned dairy farm. The property owner's goal was to build residential homes for their family. The property was part of Annexation 18 where it was pre-zoned R-1 and R-4.
- (3) The cancellation is for an alternative use which is consistent with the applicable provisions of the McFarland General Plan;
 - a. The property was part of Annexation 18 where it was prezones R-1 and R-4. Property is consistent with the General Plan. The land use for the property is Single-Family Residential and Multi-Family Residential.
- (4) The cancellation will not result in discontinuous patterns of urban development; and
 - a. Development in McFarland has sprawled out to the urban areas surrounding the City. This can be reflected in the most recent Annexations. We have multiple residential and commercial developments going out towards South Garzoli, including a new school, and commercial project proposals. That being said, a discontinuous pattern of development will not be a result of the cancellation.
- (5) There is no proximate non-contracted land which is available and suitable for the use proposed on the contracted land or that development of the contract land would provide more contiguous patterns of urban development than development of proximate non-contracted land.
 - a. The property owner group is Five Haven. They're made up of multiple families. Their goal is to construct single-family residential homes for each of them. Their purpose is not to sell these homes, but rather to provide suitable and affordable spaces for each of their families. Their purpose is consistent with the General Plan and Housing Element and will not create a discontinuous pattern of development as a result.

FINANCIAL IMPACT:

None

RECOMMENDATION:

Staff recommends approval of Resolution No. 2025-82 APPROVING the Cancellation of Land Use Restrictions, Land Conservation Act, Agriculture Preserve No. 7 and Land Use Contract.

ATTACHMENTS:

1. Site Map
2. Kern County Assessors Letter
3. Recorded Nonrenewal

RESOLUTION NO. 2025-82

A RESOLUTION OF THE CITY COUNCIL OF THE CITY OF MCFARLAND APPROVING THE CANCELLATION OF LAND USE RESTRICTIONS, LAND CONSERVATION ACT, AGRICULTURE PRESERVE NUMBER 7 AND LAND USE CONTRACT

WHEREAS, the applicant, Five Haven, has filed an application requesting the land use cancelation of a 38.18-acre parcel that is subject to Williamson Act Land Use Contract; and

WHEREAS, the parcel was annexed in 2022 through Annexation 18 and was pre-zoned R-1 and R-2 (residential); and

WHEREAS, the project sites are located on Assessor's Parcel Number 060-070-02 as depicted in Exhibit "A"; and

WHEREAS, the applicant submitted a non-renewal as reflected in Exhibit C which has since then been processed and recorded by staff; and

WHEREAS, the applicant Five Haven, shall pay the cancelation fee requested by the Kern County Assessor's office; and

WHEREAS, the applicant also submitted a Tentative Parcel Map (TPM 12606) which will be processed and presented at our future meeting; and

WHEREAS, City Council may grant a land use cancellation when all the findings are made that the cancelation is consistent with the purpose of Chapter 7 of the California Government Code Section 51282(a); and

WHEREAS, the finding was made that the cancellation is for land on which a notice of nonrenewal has been served pursuant to Section 51245;

WHEREAS, the finding was made that the cancellation is not likely to result in the removal of

adjacent lands from agricultural use;

WHEREAS, City Council and staff has found that the five (5) elements in Chapter 7 of the California Government Code Section 51282(a) have been met; and

WHEREAS, the finding was made that the cancellation is for an alternative use which is consistent with the applicable provisions of the McFarland General Plan; and

WHEREAS, the finding was made that the cancellation will not result in discontinuous patterns of urban development; and

WHEREAS, the finding was made that there is no proximate non-contracted land which is available and suitable for the use proposed on the contracted land or that development of the contract land would provide more contiguous patterns of urban development than development of proximate non-contracted land; and

WHEREAS, said applications have been made in the form and manner prescribed by Title 17 Zoning of the McFarland Municipal Code; and

WHEREAS, Pursuant to the California Environmental Quality Act (CEQA), the State Guidelines Section 15162(a) the lead agency has determined the Initial Study/ Negative Declaration that was completed for Annexation 18 to adequately identify any environmental impacts of the Project as reflected in Exhibit "A"; and

WHEREAS, the City Council, through its clerk, did set Wednesday, July 9th, 2025 at the hour of 6:00 p.m. in the Council Chambers located at 103 W. Sherwood Ave, McFarland California as the time and place for consideration and approval of the Cancelation of Land Restrictions on APN 060-070-02; and

WHEREAS, a Notice of Public Hearing was given in a manner provided in Title 17 of the McFarland Municipal Code and said public hearing was duly and timely conducted, during which the proposal was explained by a representative of the Planning Department and all person's desires were duly heard; and

WHEREAS, the City Council considered both written and oral testimony on the proposed consideration and subsequent approval of the Cancellation of Land Restrictions on APN 060-070-02; and

NOW, THEREFORE, BE IT RESOLVED, by the City Council of the City of McFarland that it hereby finds and determines as follows:

1. The foregoing recitals are true and correct.
2. That the five (5) elements in Chapter 7 of the California Government Code Section 51282 have been met.
3. Cancellation of Land Use Restrictions, Land Conservation Act, Agriculture Preserve No. 7 and Land Use Contract.
4. All provisions of CEQA and the State Guidelines have been followed. Staff determined that the previously adopted Environmental for Annexation 18 proceedings are sufficient for the processing.
5. That pursuant to the State CEQA Guidelines, the project will not result in new impacts that were not identified in the initial study.
6. The public necessity, general welfare, and good planning practices justify the Project.
7. The Project is compatible with the land use designations and development of surrounding properties and is internally consistent with the McFarland General Plan.
8. Any decision by the City Council of the City of McFarland shall have the final legislative authority to either approve or deny the proposed General Plan Amendment.

PASSED AND ADOPTED at a regular meeting of the City Council of the City of McFarland on July 9, 2025 by the following vote:

	Aye	Nae	Abstain	Absent
Saul Ayon				
Ricardo Cano				
Anita Gonzalez				
María T. Pérez				
Martin Gutierrez				

CITY OF MCFARLAND

Saul Ayon, Mayor

ATTEST:

Erika De La Cruz, City Clerk

I, _____, City Clerk of the City of McFarland, California, DO HEREBY CERTIFY that the foregoing resolution is a true and accurate copy of the Resolution passed and adopted by the City Council of the City of McFarland on the date and by the vote indicated herein.

APPROVED AS TO FORM:

Nathan Hodges, City Attorney





May 29th, 2025

Board of Supervisors
Administration Building
1115 Truxtun Avenue
Bakersfield, California 93301

Re: Cancellation of Land Use Contract

Applicant: Five Haven, LLC

Assessor's Parcel Number: 060-070-52 (25.24 acres, Ptn of 060-070-53 (12.94 acres), total
38.18 acres

Williamson Act Cancellation: no number provided

Honorable Board:

In accordance with provisions of Section 51283 of the Government Code, the Assessor certifies the fair market value and cancellation fee for the above property or a portion thereof.

CANCELLATION VALUE

\$381,800

CANCELLATION FEE

\$47,725

The Department of Conservation and/or owner may request a formal review from the Assessor of the certified value as specified in Section 51203 of the Government Code. Any request must be made within 45 days of the date of this notice.

Sincerely,

LAURA AVILA
Kern County Assessor-Recorder

Donnie Carr, Senior Appraiser
Agricultural Division

cc: Five Haven, LLC
cc: City of McFarland Planning Department



City of McFarland

City Council Meeting

STAFF REPORT

Agenda Item No. 12.
Section: ADMINISTRATIVE
AGENDA
Meeting Date: July 9, 2025

TO: Honorable Mayor and Council Members

FROM: Diego Viramontes, City Manager
Yerlys Hernandez , Public Works Director

SUBJECT: Approval of Resolution No. 2025-98 A RESOLUTION OF THE CITY COUNCIL OF THE CITY OF MCFARLAND RATIFYING THE PURCHASE AND INSTALLATION OF TRAFFIC CALMING MEASURES ON MAST AVE

SUMMARY:

The City of McFarland has received comments from concerned residents regarding the speed of vehicular traffic traveling on Mast avenue between Taylor and Hanawalt Ave.

During a subcommittee meeting with City Council on June 11th 2025, Staff was directed to install a stop sign at the intersection of Mast Ave and Mission St to try to reduce speed of vehicles driving north and south bound on Mast Ave. Staff informed the subcommittee of the criteria to have a stop sign installed which include: completing a full traffic study of the area, meeting specific requirements per the MUTCD for the volume of vehicles entering and existing the road, and the number of accidents during the last year. The last option was to hold a public hearing for the install of the stop sign. Direction given to staff was to hold a public hearing.

The Public Works department has analyzed Mast Avenue to determine the need for traffic-calming measures. The first step was to gather Accident data on Mast Avenue provided by the McFarland Police Department. There have been a total of 6 accidents since January of 2020 to Present. Its important to note that this does not report any near misses in the area.

After visually observing Mast Avenue at different times of the day during the work week, staff did notice that there are vehicles that are traveling above the designated 25 MPH speed limit.

Staff has identified areas where traffic measures could be implemented to reduce the speed of vehicles traveling north and southbound on Mast Avenue. These traffic calming measures include: Additional Speed Limit Signage, Solar Powered Radar speed limit signs, Speed Humps, Rectangular Rapid Flashing Beacons, Pavement Markings and Controlled Cross Walks. A plan is attached for reference.

In addition to the Traffic Calming measures, residents and the City council has requested a stop sign to be installed on the intersection of Mast Ave and Mission ave. Although Stop signs should not be installed for speed reducing measures per the MUTCD, a public hearing will be held before the installation of a stop sign is completed.

FINANCIAL IMPACT:

The total financial Impact for the purchase of Traffic Calming equipment and material is \$43,989.03 including Contingency to the general fund.

RECOMMENDATION:

Staff recommends approval of Resolution No. 2025 ratifying the design to purchase traffic calming equipment and material.

ATTACHMENTS:

1. Mast Ave Overall Plan
2. Mast Ave TCP - Cost Summary

RESOLUTION NO. 2025-98

A RESOLUTION OF THE CITY COUNCIL OF THE CITY OF MCFARLAND RATIFYING THE PURCHASE AND INSTALLATION OF TRAFFIC CALMING MEASURES ON MAST AVE

WHEREAS, The City of McFarland has received comments from concerned residents regarding the speed of vehicular traffic traveling on Mast avenue between Taylor and Hanawalt Ave.

WHEREAS, The Public Works department has analyzed Mast Avenue to determine the need for traffic-calming measures. The first step was to gather Accident data on Mast Avenue provided by the McFarland Police Department. There have been a total of 6 accidents since January of 2020 to Present. Its important to note that this does not report any near misses in the area.

WHEREAS, After visually observing Mast Avenue at different times of the day during the work week, staff did notice that there are vehicles that are traveling above the designated 25 MPH speed limit.

WHEREAS, Staff has identified areas where traffic measures could be implemented to reduce the speed of vehicles traveling north and southbound on Mast Avenue. These traffic calming measures include: Additional Speed Limit Signage, Solar Powered Radar speed limit signs, Speed Humps, Rectangular Rapid Flashing Beacons, Pavement Markings and Controlled Cross Walks.

WHEREAS, In addition to the Traffic Calming measures, residents and the City council has requested a stop sign to be installed on the intersection of Mast Ave and Mission ave. Although Stop signs should not be installed for speed reducing measures per the MUTCD, a public hearing will be held before the installation of a stop sign is completed.

NOW, THEREFORE, BE IT RESOLVED, by the City Council of the City of McFarland that it hereby finds and determines as follows:

1. The City Council hereby ratifies the decision to purchase traffic-calming measures and approves the plan for installation.
2. The City Council here by approves the appropriation of \$43,989.03 from the General Fund.
3. This Resolution shall become effective immediately upon adoption.

PASSED AND ADOPTED at a regular meeting of the City Council of the City of McFarland on July 9, 2025 by the following vote:

	Aye	Nae	Abstain	Absent
Saul Ayon				
Ricardo Cano				
Anita Gonzalez				
María T. Pérez				
Martin Gutierrez				

CITY OF MCFARLAND

Saul Ayon, Mayor

ATTEST:

Erika De La Cruz, City Clerk

I, _____, City Clerk of the City of McFarland, California, DO HEREBY CERTIFY that the foregoing resolution is a true and accurate copy of the Resolution passed and adopted by the City Council of the City of McFarland on the date and by the vote indicated herein.

APPROVED AS TO FORM:

Nathan Hodges, City Attorney

Mast Avenue - Speed Calming Project

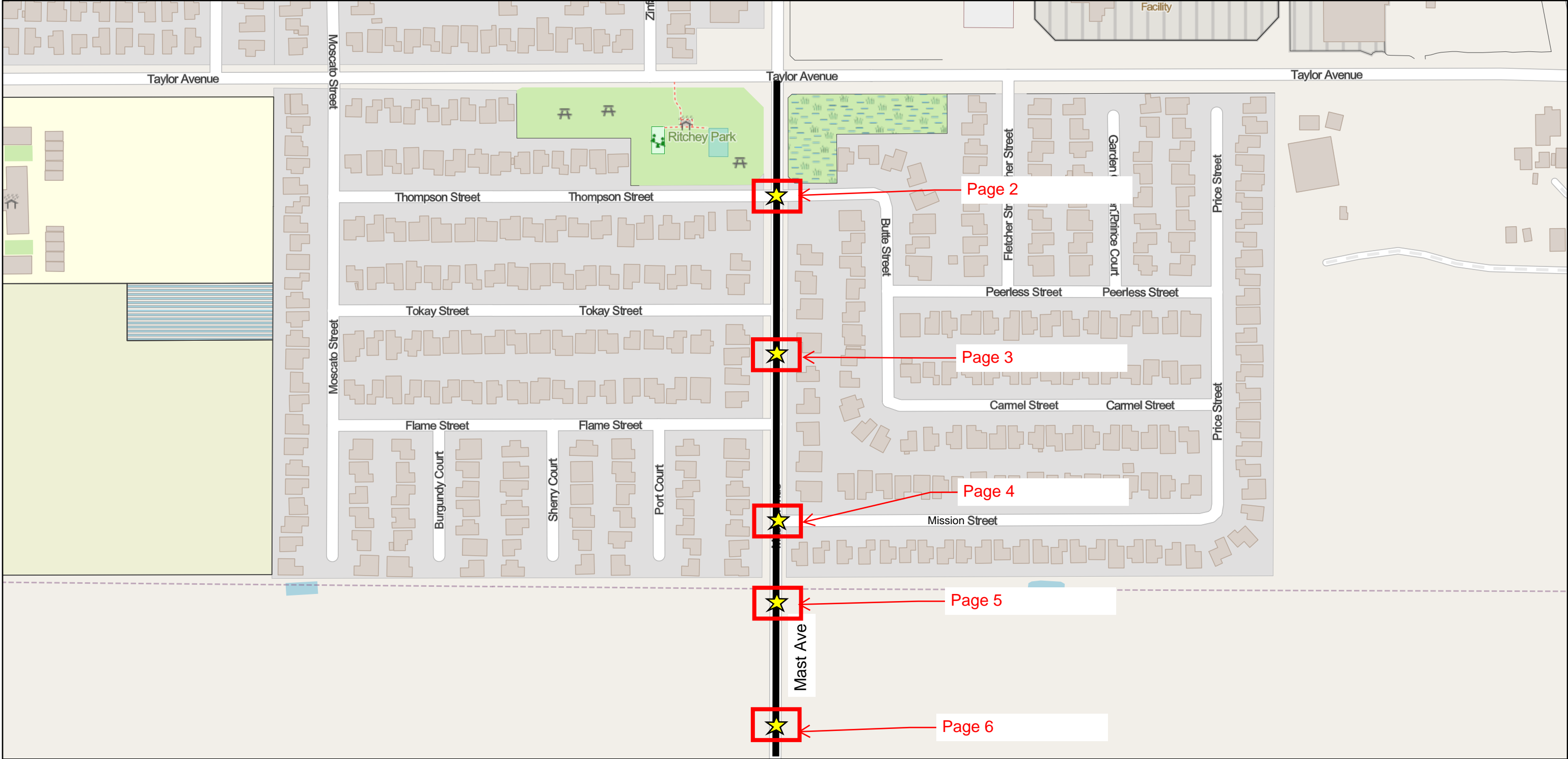

Mast Ave & Thompson St Intersection

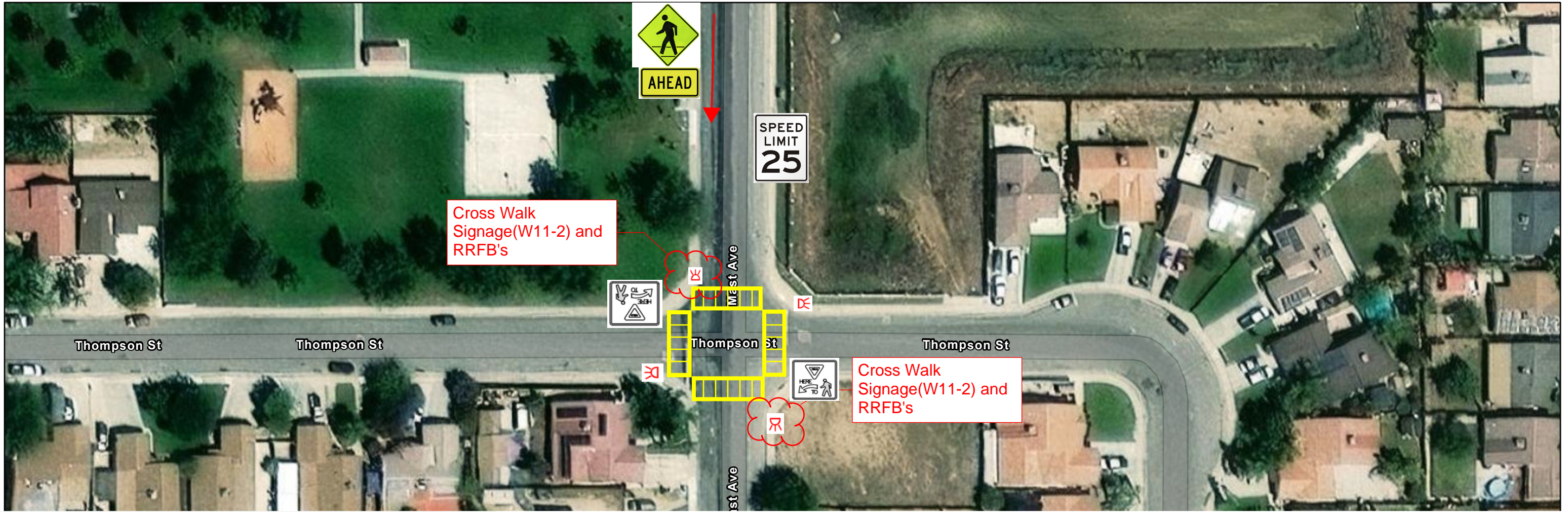

LEGEND

- "STOP" MARKING PER CALTRANS STD PLAN A24D
- "XING" MARKING PER CALTRANS STD PLAN A24D
- "SCHOOL" MARKING PER CALTRANS STD PLAN A24D
- "SLOW" MARKING PER CALTRANS STD PLAN A24D
- WHITE "YIELD LINE", PER CALTRANS STD PLAN A24G
- LADDER CROSSWALK PER CALTRANS STD PLAN A24F
- WHITE "LIMIT LINE" PER CALTRANS STD PLAN A24G
- * INSTALL ROADSIDE SIGN
- NEW ROADSIDE SIGN
- EXISTING ROADSIDE SIGN
- RECTANGULAR RAPID FLASHING BEACON (RRFB)
- LED FLASHING STOP SIGN
- GRIND AND PAVE ±3-INCH

SIGN LEGEND

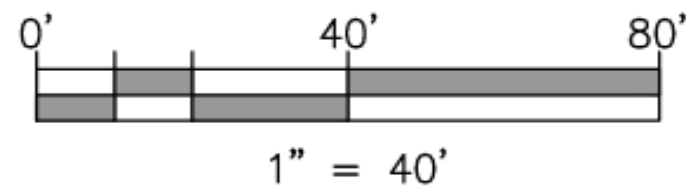

CITY OF McFARLAND
06-McFARLAND-1
IMPROVEMENTS SCHEMATICS
SITE #2

Mast Ave & Mission St Intersection

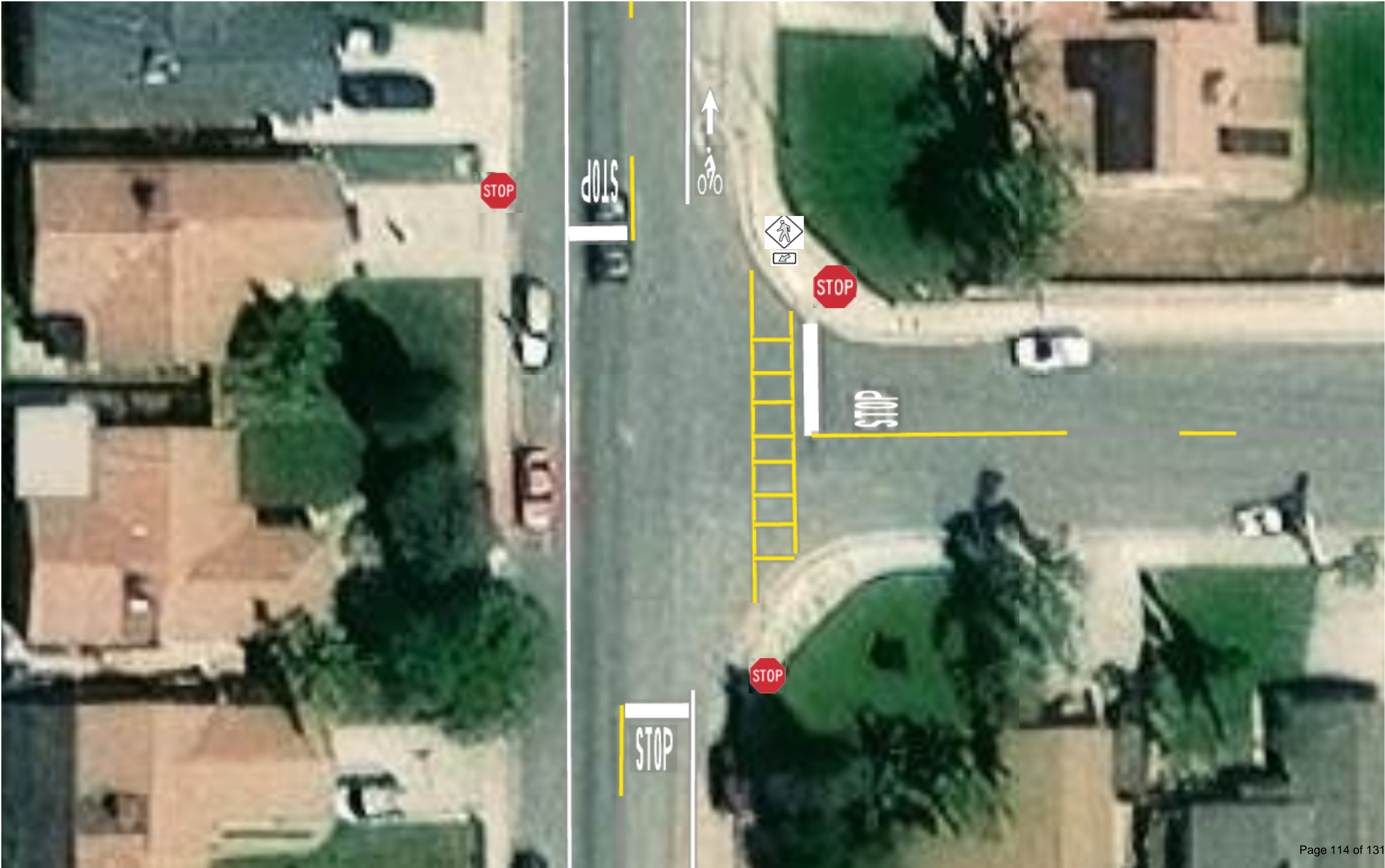

Mast Ave Entering Residential Area

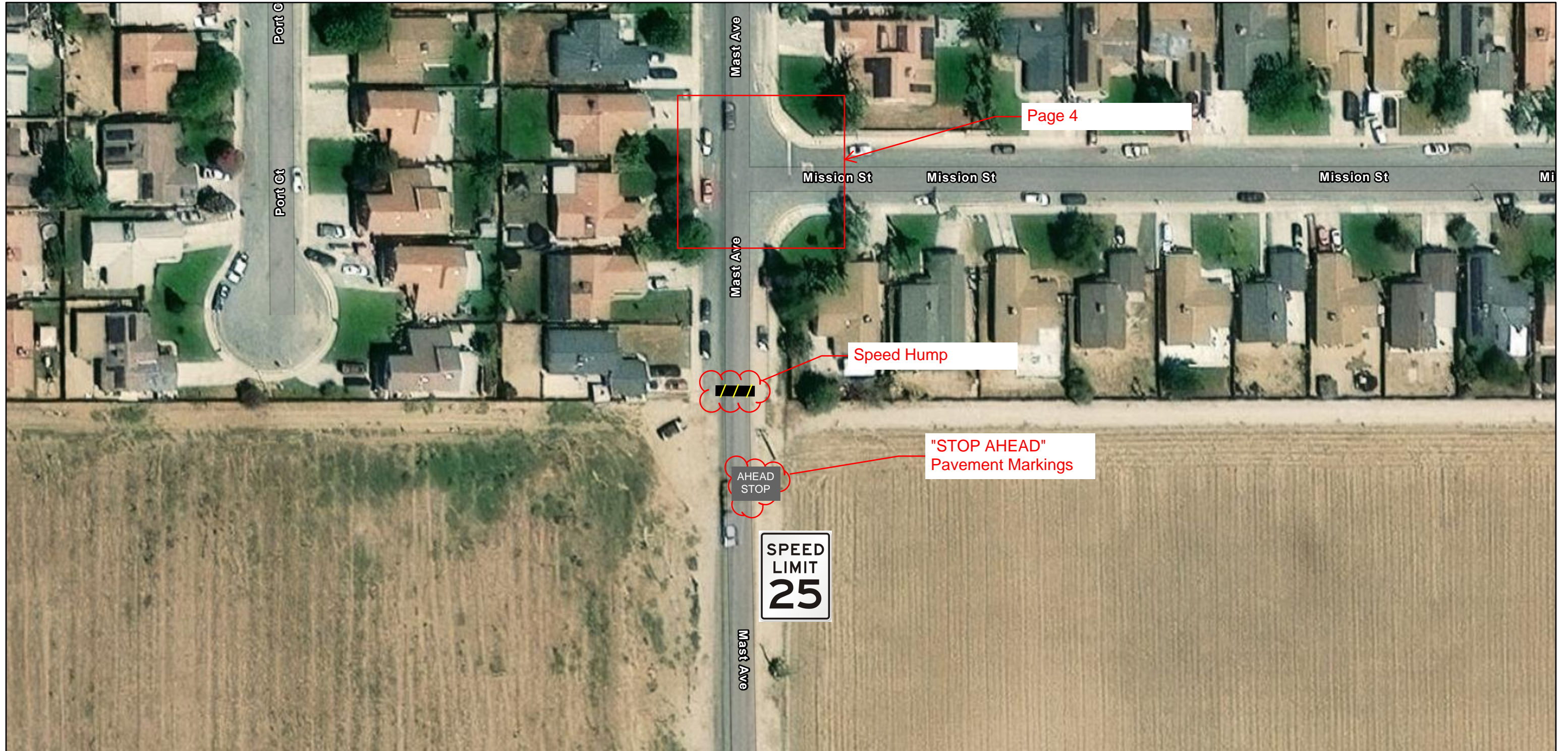

Mast Ave Traveling North from Hanawalt Ave

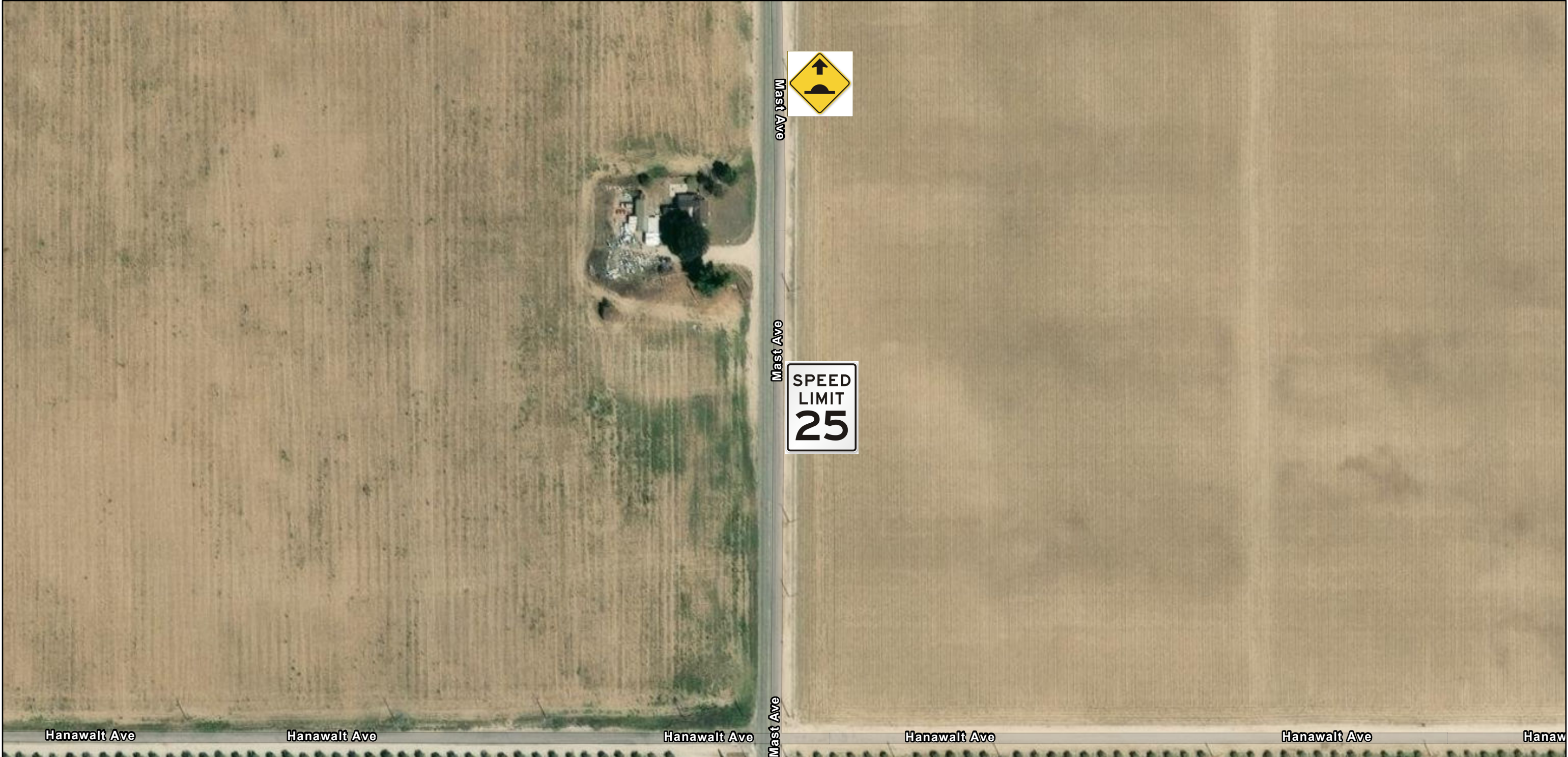

RRFB			
Description	QTY	Rate	Total
Top Of Pole RRFB RF Assembly Dual Facing. (2) Lightbar, 20 Watt Solar, 20 ah LiFe Battery, Cabinet, Controller	4	\$ 3,084.03	\$ 12,336.12
INX Polara Annunciating Push Button Station, Amber, Bluetooth With LED (R10-25 9x12) With 10' Lead In Cable	4	\$ 940.28	\$ 3,761.12
30"x30" .080 Fluorescent Yellow/Fluorescent Yellow Green With 1160i - W11-2	8	\$ 121.50	\$ 972.00
24"x12" .080 Fluorescent Yellow/Fluorescent Yellow Green With 1160i - W16-7 RIGHT	4	\$ 38.88	\$ 155.52
24"x12" .080 Fluorescent Yellow/Fluorescent Yellow Green With 1160i - W16-7 LEFT	4	\$ 38.88	\$ 155.52
Freight Charges		\$ 565.00	\$ 565.00
Total			\$ 17,945.28

Premium Speed Hump			
Description	QTY	Rate	Total
Bump - Premium Textured Speed Hump Section With 6 Yellow Stripes of Embedded Reflective Tape 20"L x 35"W x 2" H	48	\$ 94.76	\$ 4,548.48
Bump - Premium Textured Speed Hump End Cap "Female" 10"L x 35"W x 2"H	2	\$ 39.96	\$ 79.92
Bump - Premium Textured Speed Hump End Cap "Male" 10"L x 35"W x 2"H	2	\$ 5.20	\$ 79.92
Asphalt installation hardware for Speed Humps end end caps. Includes 1 piece each of 14" x 1/2" rebar spike and 5/8" washer	300	\$ 850.00	\$ 1,560.00
Freight Charges	1	\$ 850.00	\$ 850.00
Total			\$ 7,118.32

Speed Limit Sign			
Description	QTY	Rate	Total
Safespace Evolution 15, 15" Digit Size. W/Bluetooth, 1 YR Free Cloud Trial Solar Radar Sign	2	\$ 4,012.00	\$ 8,024.00
Freight Charges	1	\$ 750.00	\$ 750.00
Total			\$ 8,774.00

SLOW Blinker Sign			
Description	QTY	Rate	Total
Solar Blinker Sign - W42-8, SLOW SIGN, 30", AMBER LEDs (8), 3M DG REFLECTIVE SHEETING FLUORESCENT YELLOW, SOLAR POWERED, LITHIUM BATTERY PACKAGE 24/7	2	\$ 1,780.52	\$ 3,561.04
Freight Charges - Manufacture to KRC	1	\$ 550.00	\$ 550.00
Sales Tax (8.5%)			\$ 302.69
Total			\$ 4,413.73

Total \$ 38,251.33
 Contingency 15% \$ 5,737.70
Total Cost \$ 43,989.03



License #507950 (A,C31)
 DBE #000447
 SBE #6897
 MBE #9IS00114
 DIR #1000004730

Sales Quote

Date	Estimate #
6/27/2025	25-785

Name / Address
CITY OF MCFARLAND 401 W. KERN AVE. MCFARLAND, CA 93250

Ship To

7821 W. Sunnyview Visalia, CA 93291 Ph# 559-732-0393 Fax# 559-732-2684 Visit us online @ www.krcsafety.com	Rep	Project #	P.O. No.
	MikeC		

Description	Qty	Rate	Total
Top Of Pole RRFB RF Assembly Dual Facing, (2) Lightbar, 20 Watt Solar, 20ah LiFe Battery, Cabinet, Controller	4	3,084.03	12,336.12T
INX Polara Annunciating Push Button Station, Amber, Bluetooth With LED (R10-25 9x12) With 10' Lead In Cable	4	940.28	3,761.12T
30"x30" .080 Fluorescent Yellow/Fluorescent Yellow Green With 1160i - W11-2	8	121.50	972.00T
24"x12" .080 Fluorescent Yellow/Fluorescent Yellow Green With 1160i - W16-7 RIGHT	4	38.88	155.52T
24"x12" .080 Fluorescent Yellow/Fluorescent Yellow Green With 1160i - W16-7 LEFT	4	38.88	155.52T
Freight Charges		565.00	565.00

- Quote good for 30 days from quote date. - 3% fee will be charged on all credit card transactions - Payment terms are NET 30 unless stated differently on quote. An additional 2% per month interest charge will be charged on all invoices not paid within 30 days. This rate is based on your past due balance at the end of each billing period. - Applicable sales tax will be added at time of delivery. - Unless otherwise noted contractor is responsible for all unloading and loading of materials.	Subtotal	\$17,945.28
	Sales Tax (0.0%)	\$0.00
	Total	\$17,945.28

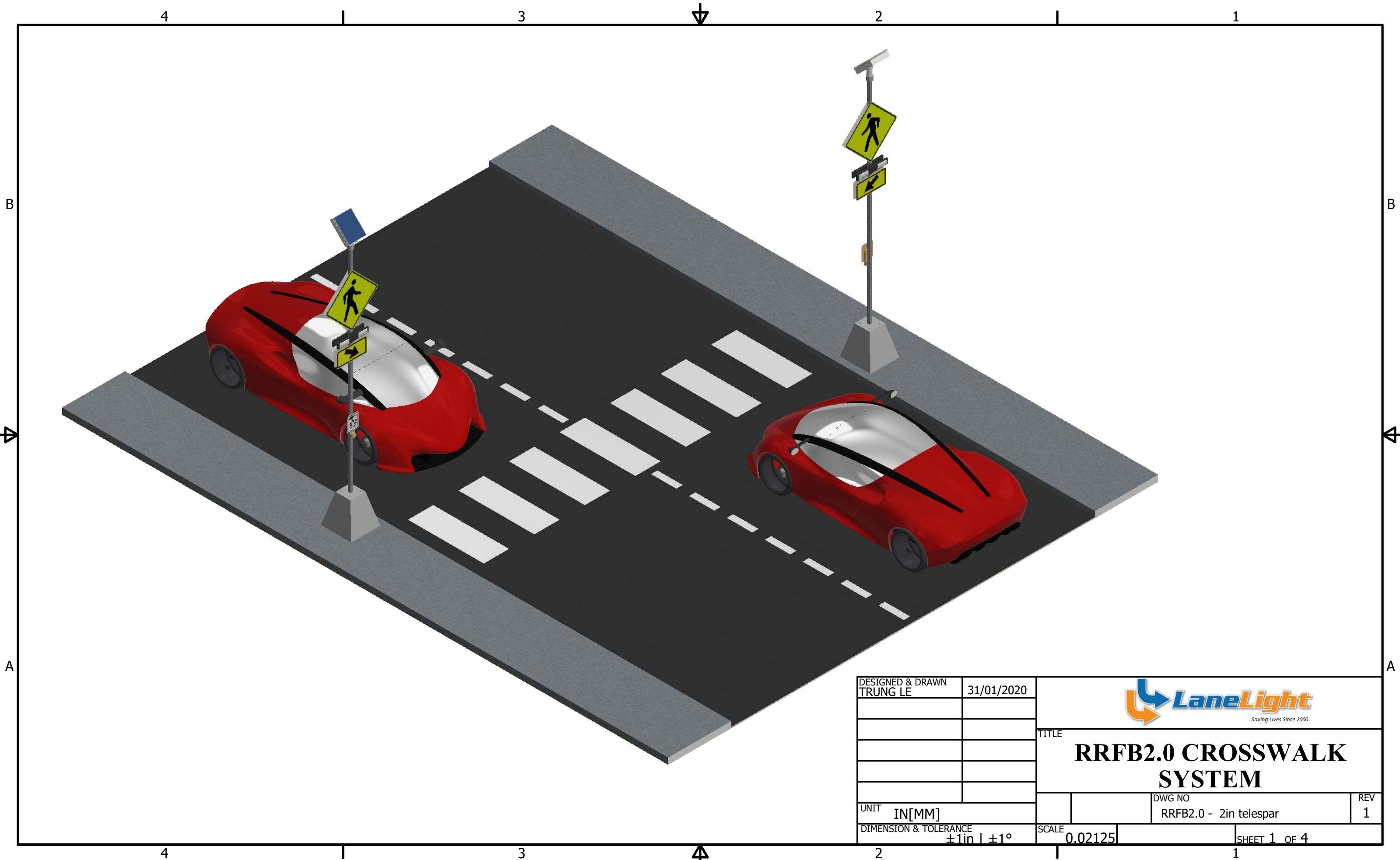

DESIGNED & DRAWN TRUNG LE	31/01/2020	 <small>Saving Lives Since 2000</small>	
		TITLE	
		RRFB2.0 CROSSWALK SYSTEM	
UNIT	IN[MM]	DWG NO	REV
		RRFB2.0 - 2in telespar	1
DIMENSION & TOLERANCE ±1in ±1°		SCALE	SHEET 1 OF 4
		0.02125	

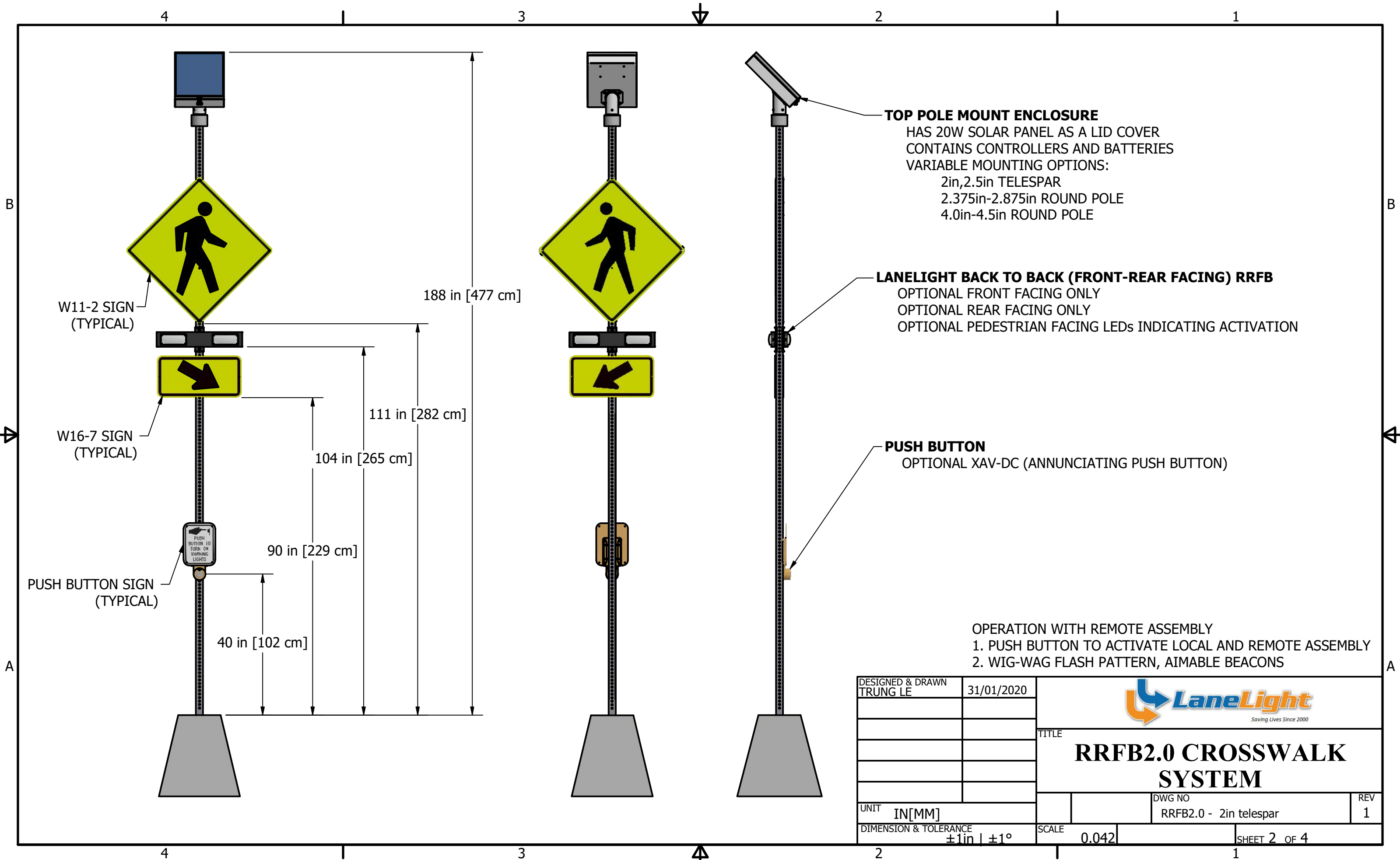

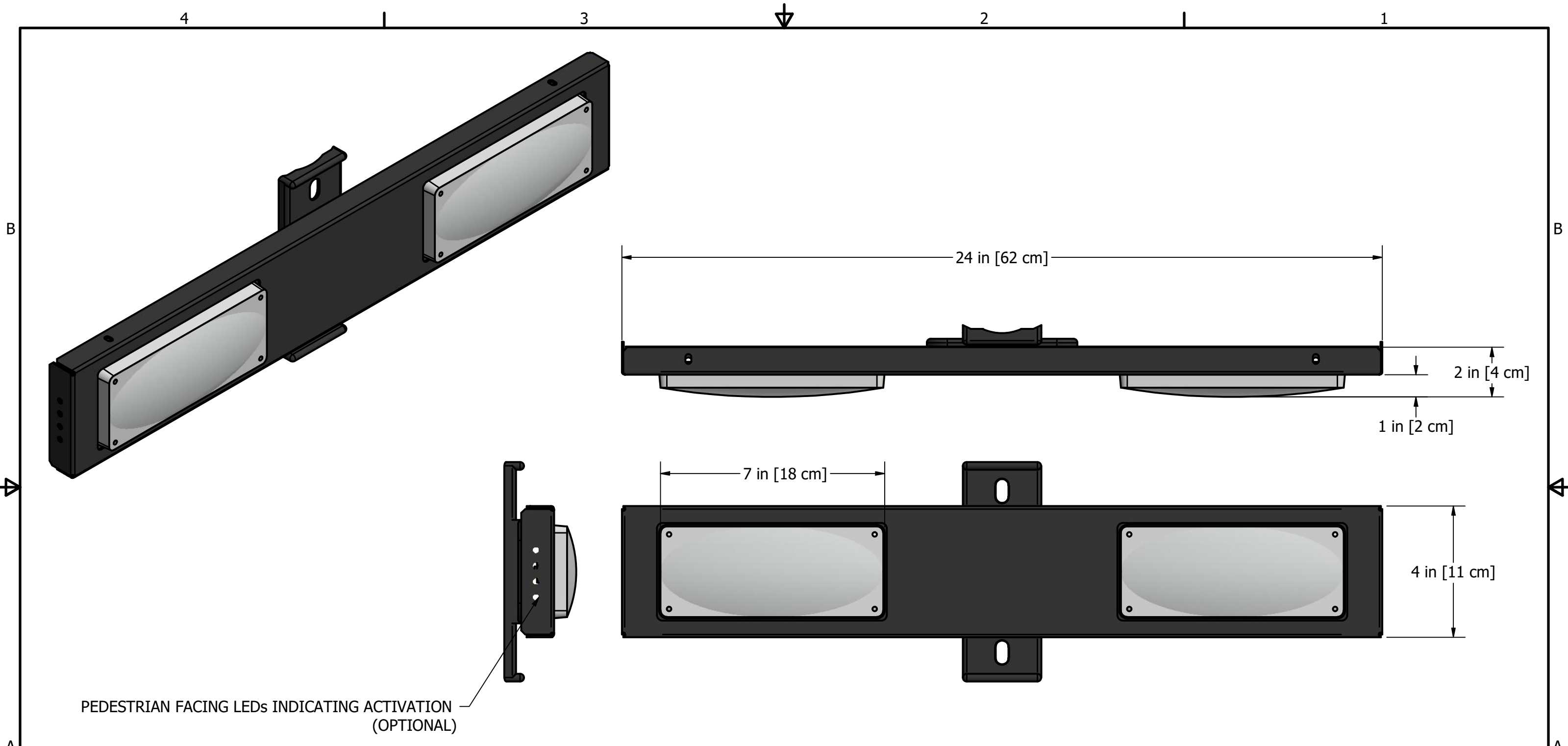



PEDESTRIAN FACING LEDs INDICATING ACTIVATION
(OPTIONAL)

RRFB

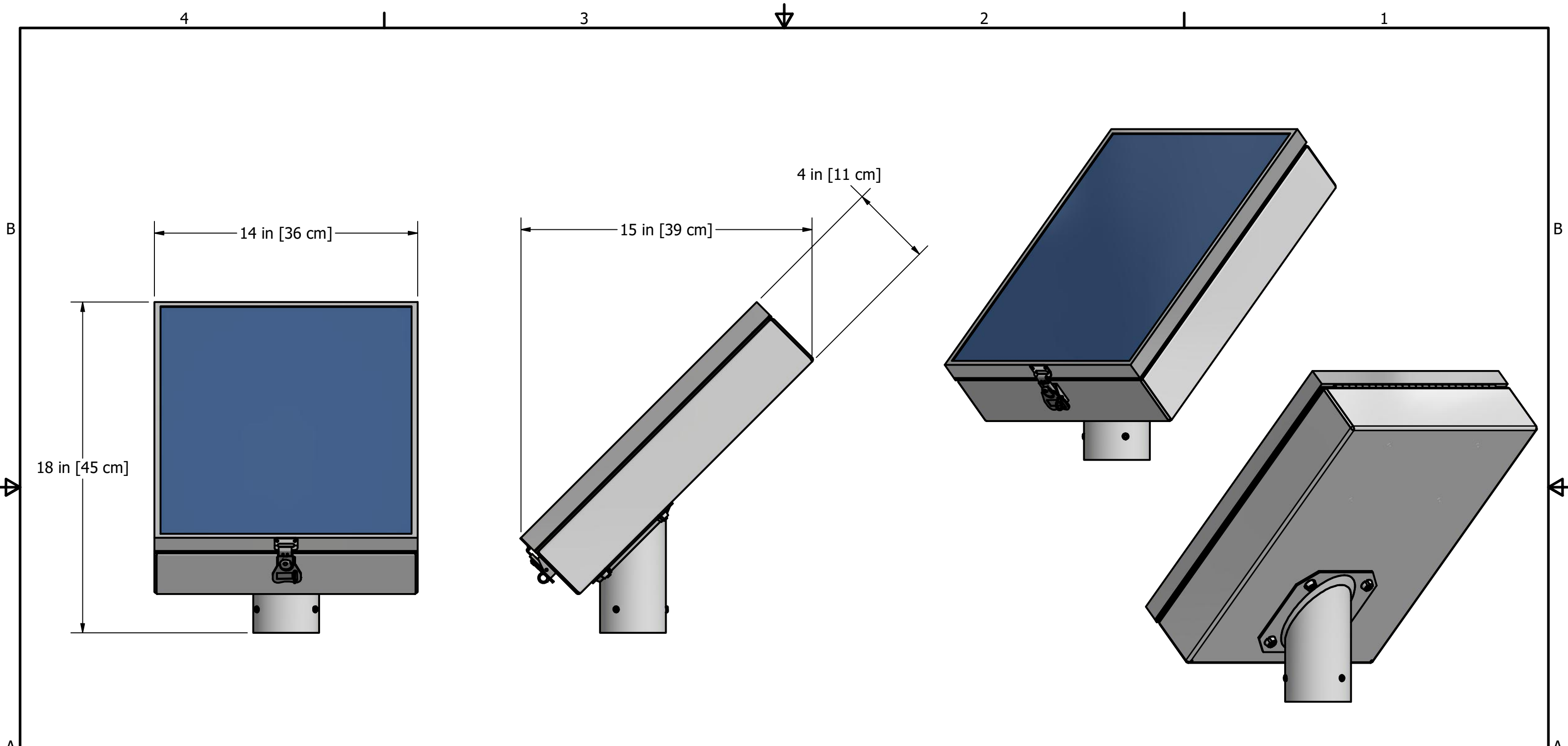
DESIGNED & DRAWN TRUNG LE	31/01/2020	 RRFB2.0 CROSSWALK SYSTEM	
		TITLE	
		RRFB2.0 CROSSWALK SYSTEM	
UNIT IN[MM]		DWG NO RRFB2.0 - 2in telespar	REV 1
DIMENSION & TOLERANCE ±1in ±1°	SCALE 1 / 3	SHEET 3 OF 4	



TOP POLE MOUNT ENCLOSURE

DESIGNED & DRAWN TRUNG LE	31/01/2020	 RRFB2.0 CROSSWALK SYSTEM	
		TITLE	
		RRFB2.0 - 2in telespar	
UNIT IN[MM]		DWG NO	REV
DIMENSION & TOLERANCE ±1in ±1°	SCALE 1 / 5	RRFB2.0 - 2in telespar	1
		SHEET 4 OF 4	



License #507950 (A,C31)
 DBE #000447
 SBE #6897
 MBE #9IS00114
 DIR #1000004730

Sales Quote

Date	Estimate #
6/27/2025	25-786

Name / Address
CITY OF MCFARLAND 401 W. KERN AVE. MCFARLAND, CA 93250

Ship To

7821 W. Sunnyview Visalia, CA 93291 Ph# 559-732-0393 Fax# 559-732-2684 Visit us online @ www.krcsafety.com	Rep	Project #	P.O. No.
	MikeC		

Description	Qty	Rate	Total
Bump - Premium Textured Speed Hump Section With 6 Yellow Stripes of Embedded Reflective Tape 20"L x 35"W x 2"H.	48	94.76	4,548.48T
Bump - Premium Textured Speed Hump End Cap "Female" 10"L x 35"W x 2"H.	2	39.96	79.92T
Bump - Premium Textured Speed Hump End Cap "Male" 10"L x 35"W x 2"H.	2	39.96	79.92T
Asphalt installation hardware for Speed Humps and end caps. Includes 1 piece each of 14" x 1/2" rebar spike and 5/8" washer	300	5.20	1,560.00T
Freight Charges	1	850.00	850.00

- Quote good for 30 days from quote date. - 3% fee will be charged on all credit card transactions - Payment terms are NET 30 unless stated differently on quote. An additional 2% per month interest charge will be charged on all invoices not paid within 30 days. This rate is based on your past due balance at the end of each billing period. - Applicable sales tax will be added at time of delivery. - Unless otherwise noted contractor is responsible for all unloading and loading of materials.	Subtotal	\$7,118.32
	Sales Tax (0.0%)	\$0.00
	Total	\$7,118.32

SPEED BUMPS, SPEED HUMPS & CAR STOPS

PLASTICADE®

Plasticade.com

- Resistant to weather, oil, salt, moisture, UV light, and temperature
- Will not warp, chip, or crack
- Never needs painting, durable striping
- 44,000 lbs./axle weight bearing capacity
- Flexible, conforms to surface contours
- Install on asphalt or concrete (hardware sold separately)
- Removable for road surface maintenance or snow plowing

SPEED BUMPS



Standard Speed Bump

- 2.5" High, 6' or 4' sections, made from recycled rubber
- Reflective yellow tape is embedded in the rubber, increases visibility
- Good for parking lots & slow roadways, reduces speeds 2-5 mph
- Cut with a utility knife if necessary
- Optional cat eye reflectors
- Dual bottom channels for drainage, protects wire, hose, or pipe
- End caps and hardware sold separately
- Made in the USA



Premium Textured Speed Bump

- 2" High, 6' sections
- Use in heavy traffic areas on low speed roadways
- Reduces speeds 1-5 mph
- Textured, vulcanized rubber performs well in extreme temperatures
- Cat eye reflectors included for increased visibility at night
- 5 synthetic rubber yellow stripes, (EPDM) won't degrade
- Dual bottom channels for drainage - protects wire, hose, or pipe
- End caps and hardware sold separately

SPEED HUMPS



Standard Speed Hump

- 2.4" High, 24" sections, made from recycled rubber
- For traffic speeds 15 mph or less
- Gentler than speed bumps
 - good for heavy truck traffic areas
- Reflective stripes in yellow
- Dual bottom channels for drainage
 - protects wire, hose, or pipe to 3/4" dia.
- Made in the USA



Premium Textured Speed Hump

- 2" High, 20" sections
- Use in heavy traffic areas
- Made of durable vulcanized rubber
 - performs well in extreme temperatures
- Textured surface helps with traction
- 6 rectangular yellow stripes per section
 - high visibility, non-wearing color

PARKING STOPS



- Use in parking lots and garages
 - protects garage walls, delineates spaces
- Available in 6 foot or 4 foot lengths
- Maintenance Free
- High visibility at night
 - reflective stripes in yellow or white
- Made in the USA using recycled rubber



SPEED BUMPS, SPEED HUMPS & CAR STOPS

SPEED BUMPS

Low Profile & Standard End Cap



Premium End Cap



Channels for drainage or protect wire, hose, or pipe see spec. sheet for more information



Back View

SPEED HUMPS

Standard Speed Hump

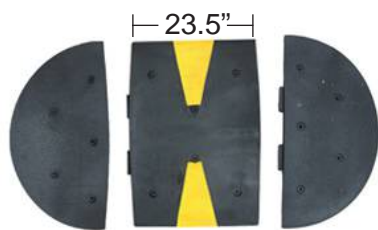

Female End Cap Center Section Male End Cap

Channels for drainage or protect wire, hose, or pipe to 3/4" dia.

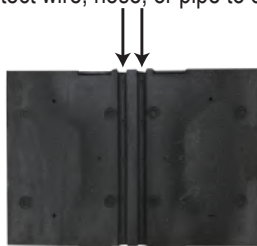

Back View of Standard Speed Hump

Premium Speed Hump

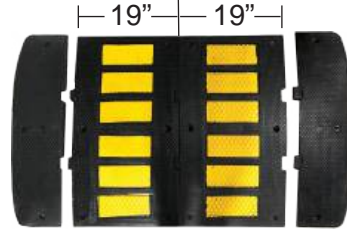

Female End Cap Center Sections Male End Cap



Back View of Premium Speed Hump

PARKING STOPS



Back View

Speed Bump

Dimensions	4' 48"L x 12"W, 35 lbs. 6' 72"L x 12"W, 52 lbs.
End Cap	7"L x 12"W, 3.5 lbs.
Stripes	72" - 3 yellow 48" - 2 yellow
Cat Eyes	72" - 8 48" - 6
Installation Holes	72" - 4 48" - 3 End Cap - 2

Premium Speed Bump

Dimensions	72"L x 12"W x 2"H, 52 lbs.
End Caps	6"L x 12"W x 2"H, 3.5 lbs.
Stripes	5 yellow
Cat Eyes	8
Installation Holes	4 End Cap - 1

Standard Speed Hump

Dimensions	24"L x 36"W x 2.4"H, 52 lbs. connected length - 23.5"
End Caps	17.5"W x 36"W x 2.4"H, 23 lbs.
Stripes	2 yellow, per center section
Installation Holes	Center Section - 6 End Cap - 5

Premium Speed Hump

Dimensions	20"L x 35"W x 2"H, 38 lbs. connected length - 19"
End Caps	10"L x 35"W x 2"H, 14 lbs.
Stripes	6 yellow, per center section
Installation Holes	Center Section - 6 End Cap - 3

Parking Stops

Dimensions	72"L x 6"W x 4.5"H, 35.5 lbs. 48"L x 6"W x 4.5"H, 30 lbs.
Stripes	Yellow on black stop White on black or blue stop 72" - 4 on each side of stop 48" - 2 on each side (yellow)
Installation Holes	72" - 4 holes 48" - 3 holes

Installation Hardware



- Concrete
 - 4 1/2" Lag Bolt with Washer & Shield for Speed Bumps & Speed Humps
 - 6" Lag Bolt with Washer & Shield for Car Stops
- Asphalt
 - 14" Re-bar Spike with Washer
- Epoxy can be used in addition to or as a replacement for the hardware in certain applications. See the installation instructions on our website.

Dimensions listed are nominal. For critical applications, a sample of current production parts should be evaluated.

PLASTICADE®

100 Howard Avenue
Des Plaines, IL 60018
phone (800) 772-0355
info@plasticade.com

Plasticade.com



SafePace[®] Evolution 15

The Traffic Logix SafePace[®] Evolution 15 is the lightweight sign with full size impact.

The Traffic Logix SafePace 15 driver feedback sign is a portable, lightweight radar sign with full size 15" digits. A speed activated message to slow down alerts speeding drivers. Digits are dual color while messaging is available in a choice of red or amber. The Evolution 15 sign can be mounted at multiple locations with universal mounting options and can function autonomously for weeks at a time with optional battery power.

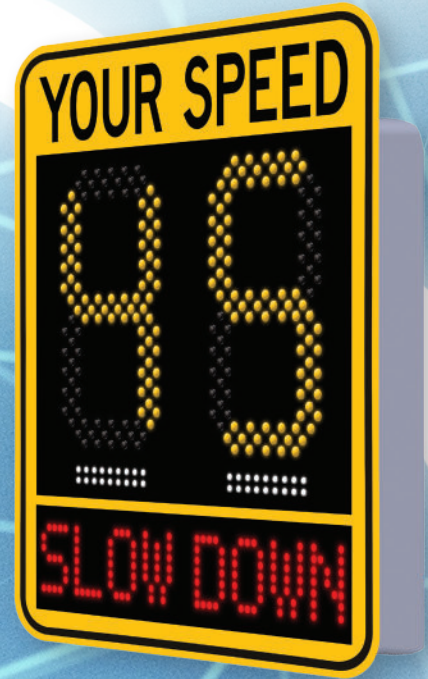

EV 15 Specifications	
Digit Size	15"
Height	33.1"
Weight	28 lbs
24/7, 365 Scheduling	✓
Data Collection	✓
Solar Compatibility	✓
Battery Operated	✓
Universal Mounting	✓
Cloud Compatibility	✓
Trailer Compatibility	✓
Dolly Compatibility	✓
Hitch Compatibility	✓
Warranty	2 Years

Features
MUTCD compliant with static "YOUR SPEED" message and highly visible 15" LED digits that are visible from up to 600 ft away.
Dual Color Display: LED digit color can be programmed to change based on driver speed
User-friendly software interface allows you to manage sign parameters such as threshold speeds and violator strobe remotely.
Ultra-low power consumption including the most power-efficient radar technology available, optional solar power.
Stealth Mode allows the sign to collect baseline traffic data while speed display appears blank to motorists.
Slow Down Messaging: Sign flashes "Slow Down" message at drivers who exceed designated speed.
Superior construction and durability for long-lasting performance.
Universal Mounting: Optional mounting brackets let you use one sign at multiple locations with the turn of a key.

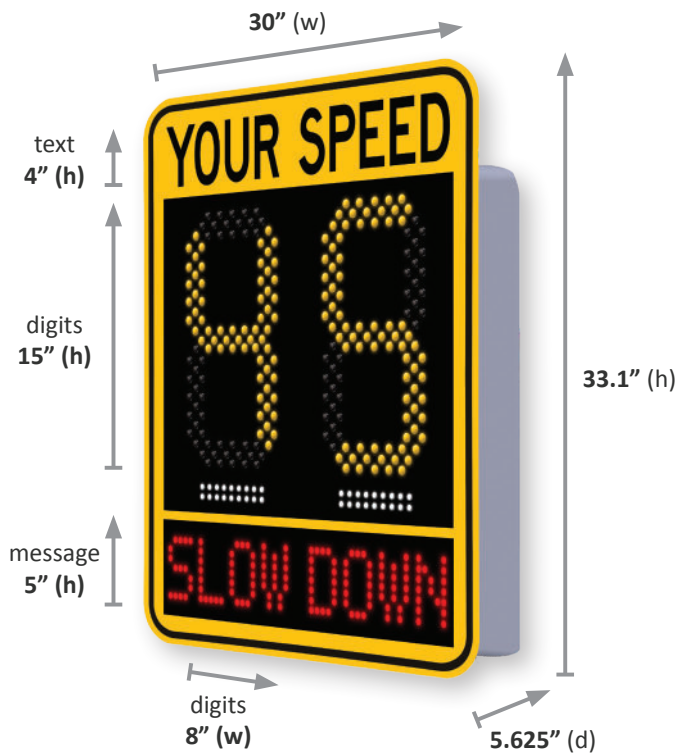

Feature	Specifications
Dimensions	
Digits	15"(h) x 8"(w)
LED Message Text	Letters 5"(h) spell "SLOW DOWN", 1line
Unit with "YOUR SPEED" sign mounted	Full size sign: 33.1"(h) x 30"(w) x 5.625"(d)
Sign Weight (includes "YOUR SPEED" sign (2 lbs) mounted)	
AC Powered	28 lbs
Battery Powered Model	28 lbs (not including batteries)
Solar powered model	28 lbs (does not include batteries, solar panel or bracket)
General Specifications	
Operating Temperatures F (C):	-40° (-40°) to 185° (85°)
3-Digit Speed Display with Slow Down message	Miles per hour (mph) 3-99. Kilometers per hour (km/h) 5-160.
Faceplate	High-Intensity prismatic reflective sheeting on "YOUR SPEED" signs with black colored text. MUTCD approved colors and format
Communications	Bluetooth, GSM/GPRS
Programming	SafePace® Pro management software SafePace® Cloud remote management 24/7 365 day unlimited programming and scheduling

Feature	Specifications
Power Options (Electrical Specifications)	
AC power input	100~240 V AC
DC power input	12 V DC
DC battery options	12V, 18Ah Lead acid batteries
Solar panel option	50W or 90W solar panel
Radar	
Internal Radar:	Doppler (FCC approved)
Model	DF 300
Radar RF out	5 mW maximum
Radar f-center	24.125 GHz center +/- 25 MHz
Pickup distance	Up to 1,200 feet
Beam angle	24° (vertical) x 12° (horizontal)
Beam polarization	Linear
CE Mark (Radar)	Yes
Display	
LEDs	484
Digits (Amber)	224 LEDs: Color: Yellow (590 nm) Viewing angle at 50% IV: 30° Partial Flux (Brightness): 9000 – 22400 Ev,[lux]/LED
Digits (Red)	224 LEDs: Color: Red (633 nm) Viewing angle at 50% IV: 30° Partial Flux (Brightness): 7100 – 18000 Ev,[lux]/LED
Slow Down Message	227 LEDs: Color: Red 633 nm) Viewing angle at 50% IV: 30° Partial Flux (Brightness): 7100 – 18000 Ev,[lux]/LED
Speed Violator Strobes	36 LEDs: Color: White (2700 K – 6500 K) Viewing angle at 50% IV: 150° Luminous Flux: typically 33lm @ 4000 K Luminous Efficacy: typically 176 lm/W @4000 K
Ambient light sensor	1 sensor and automatic brightness adjustment
Enclosure	
Construction	Vandal resistant, lightweight polymer. Matte black front for reduced glare and maximum contrast. Light gray body to minimize heat absorption
Weatherproof Rating	Weatherproof, NEMA 3, IP55 level compliant. Non-sealed and ventilated
Warranty	
Sign	2 years
Batteries	1 year



SafePace® Evolution 15SL

The Traffic Logix SafePace® Evolution 15SL is the lightweight sign with full size impact.

The Traffic Logix SafePace Evolution 15SL driver feedback sign is a portable, lightweight radar sign with full size 15” digits. Speed activated messages alert speeding drivers. Digits are tri-color while variable messaging is available in amber. The Evolution 15SL sign can be mounted at multiple locations with universal mounting options and can function autonomously for weeks at a time with optional battery power.



EV 15SL Specifications	
Digit Size	15”
Height	33.1”
Weight	28 lbs
24/7, 365 Scheduling	✓
Data Collection	✓
Solar Compatibility	✓
Battery Operated	✓
Universal Mounting	✓
Cloud Compatibility	✓
Trailer Compatibility	✓
Dolly Compatibility	✓
Hitch Compatibility	✓
Warranty	2 Years

Features
MUTCD compliant with static “YOUR SPEED” message and highly visible 15” LED digits that are visible from up to 600 ft away.
Tri-Color Display: LED digit color can be programmed to change based on driver speed
User-friendly software interface allows you to manage sign parameters such as threshold speeds and violator strobe remotely.
Ultra-low power consumption including the most power-efficient radar technology available, optional solar power.
Stealth Mode allows the sign to collect baseline traffic data while speed display appears blank to motorists.
Slow Down Messaging: Sign flashes variable messages at drivers who exceed the speed limit.
Superior construction and durability for long-lasting performance.
Universal Mounting: Optional mounting brackets let you use one sign at multiple locations with the turn of a key.

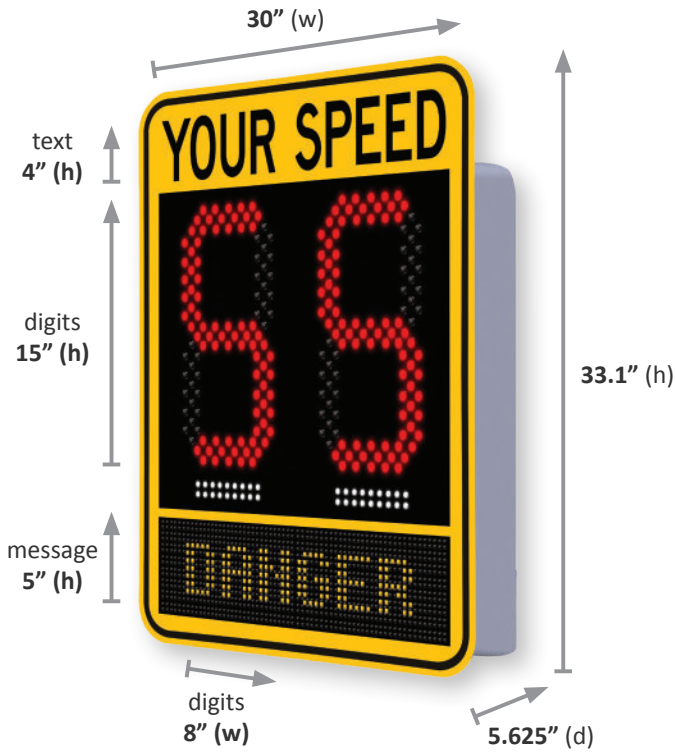

Feature	Specifications
Dimensions	
Digits	First Digit: 15"(h) x 1.5"(w) Other Digits: 15"(h) x 8"(w)
LED Message Text	Letters 5"(h), 1line
Unit with "YOUR SPEED" sign mounted	Full size sign: 33.1"(h) x 30"(w) x 5.625"(d)
Sign Weight (includes "YOUR SPEED" sign (2 lbs) mounted)	
AC Powered	28 lbs
Battery Powered Model	28 lbs (not including batteries)
Solar powered model	28 lbs (does not include batteries, solar panel or bracket)
General Specifications	
Operating Temperatures F (C):	-40° (-40°) to 185° (85°)
3-Digit Speed Display with variable message	Miles per hour (mph) 3-99. Kilometers per hour (km/h) 5-160.
Faceplate	High-Intensity prismatic reflective sheeting on "YOUR SPEED" signs with black colored text. MUTCD approved colors and format
Communications	Bluetooth, GSM/GPRS
Programming	SafePace® Pro management software SafePace® Cloud remote management 24/7 365 day unlimited programming and scheduling

Feature	Specifications
Power Options (Electrical Specifications)	
AC power input	100~240 V AC
DC power input	12 V DC
DC battery options	12V, 18Ah Lead acid batteries
Solar panel option	50W or 90W solar panel
Radar	
Internal Radar:	Doppler (FCC approved)
Model	DF 300
Radar RF out	5 mW maximum
Radar f-center	24.125 GHz center +/- 25 MHz
Pickup distance	Up to 1,200 feet
Beam angle	24° (vertical) x 12° (horizontal)
Beam polarization	Linear
CE Mark (Radar)	Yes
Display	
LEDs	484
Digits (Green)	256 LEDs: Color: Green (590 nm) Viewing angle at 50% IV: 30° Partial Flux (Brightness): 9000 – 22400 Ev,[lux]/LED
Digits (Red)	256 LEDs: Color: Red (633 nm) Viewing angle at 50% IV: 30° Partial Flux (Brightness): 7100 – 18000 Ev,[lux]/LED
Variable Messages	1024 LEDs: Color: Amber 633 nm) Viewing angle at 50% IV: 30° Partial Flux (Brightness): 7100 – 18000 Ev,[lux]/LED
Speed Violator Strobes	36 LEDs: Color: White (2700 K – 6500 K) Viewing angle at 50% IV: 150° Luminous Flux: typically 33lm @ 4000 K Luminous Efficacy: typically 176 lm/W @4000 K
Ambient light sensor	1 sensor and automatic brightness adjustment
Enclosure	
Construction	Vandal resistant, lightweight polymer. Matte black front for reduced glare and maximum contrast. Light gray body to minimize heat absorption
Weatherproof Rating	Weatherproof, NEMA 3, IP55 level compliant. Non-sealed and ventilated
Warranty	
Sign	2 years
Batteries	1 year



License #507950 (A,C31)
 DBE #000447
 SBE #6897
 MBE #9IS00114
 DIR #1000004730

Sales Quote

Date	Estimate #
7/2/2025	25-800

Name / Address
CITY OF MCFARLAND 401 W. KERN AVE. MCFARLAND, CA 93250

Ship To

7821 W. Sunnyview Visalia, CA 93291 Ph# 559-732-0393 Fax# 559-732-2684 Visit us online @ www.krcsafety.com	Rep	Project #	P.O. No.
	MikeC		

Description	Qty	Rate	Total
Solar Blinker Sign - W42-8, SLOW SIGN, 30", AMBER LEDs (8), 3M DG REFLECTIVE SHEETING FLUORESCENT YELLOW, SOLAR POWERED, LITHIUM BATTERY PACKAGE 24/7	2	1,780.52	3,561.04T
Freight Charges - Manufacture to KRC	1	550.00	550.00

- Quote good for 30 days from quote date. - 3% fee will be charged on all credit card transactions - Payment terms are NET 30 unless stated differently on quote. An additional 2% per month interest charge will be charged on all invoices not paid within 30 days. This rate is based on your past due balance at the end of each billing period. - Applicable sales tax will be added at time of delivery. - Unless otherwise noted contractor is responsible for all unloading and loading of materials.	Subtotal	\$4,111.04
	Sales Tax (8.5%)	\$302.69
	Total	\$4,413.73